

ECOWATER
S Y S T E M S®



Your Water. Perfected.

Undersink
REVERSE OSMOSIS
DRINKING WATER SYSTEM

ERO-375
ERO-375E
HERO-375Plus

- ◆ Safety Guides
 - ◆ Installation
 - ◆ Operation
 - ◆ Maintenance
 - ◆ Repair Parts

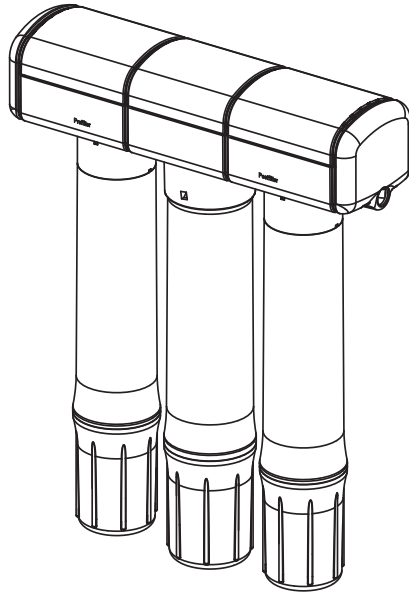

Designed, Engineered &
Assembled in the U.S.A.

EcoWater Systems LLC
P.O. Box 64420
St. Paul, MN 55164
www.ecowater.com

Systems tested and certified by
NSF International against NSF/ANSI
Standards 42 & 58. See perform-
ance data on page 26 for details.



201-8404411 (Rev. 02 6/8/17)

TABLE OF CONTENTS

Warranty Information	2	Installing (or Replacing) Batteries.	12
Safety Guides	3	Connecting Hydrolink Plus® to Wi-Fi	13-14
Specifications	4	Checking Batteries & Connection	13
What the Drinking Water System Will Do	5	Connect Mode.	13
Components of the System.	5	Connect to Wi-Fi Using the App.	13-14
Checks to Make Before Installing	5	Register Device / Setup Alerts	14
Installing	6-14	Wi-Fi Data / Alerts	15
Feed Water Supply.	6	Position Hydrolink Plus® Under the RO Cover.	15
Reject Water Drain Fitting.	6	How the RO System Works	16
Installing Faucet	7	Replacing the Filters & RO Membrane	17
Installing RO Assembly & Storage Tank	8	Care of Your Reverse Osmosis System.	17-20
Tubing Connections.	9	Troubleshooting	20
Connect Water Supply, Storage Tank		System Schematic.	21
& Drain Tubing	10	Installation of Optional Fittings	22
Sanitizing / Pressure Testing / Purging	11	Remote Location Installation	23
Installing Hydrolink Plus® RO Module	12	Repair Parts	24-25
		Performance Data	26-28

WARRANTY INFORMATION

LIMITED WARRANTY 1, 3, 5, 7 and 10 YEAR

EcoWater Systems LLC, guarantees to the original owner that: for a period of ten (10) years from the date of purchase, the RO holding tank will be free from defects in material and workmanship. The electronics, including the Hydrolink Plus® module, will be guaranteed for a period of seven (7) years from defects in material and workmanship. The faucet will be guaranteed for a period of three (3) years from defects in material and workmanship. The reverse osmosis membrane will be guaranteed for a period of one (1) year from defects in material and workmanship. All other parts of the drinking water system will be guaranteed for a period of five (5) years from defects in material and workmanship. The prefilters and postfilter, which are expendable, are not covered under this warranty. This warranty does not include normal shipping, installation or service charges.

Any defective part, as described above, which fails within the ten, seven, five, three or one year period from date of purchase will be repaired or replaced, F.O.B. our plant, St. Paul, MN.

The sole obligation of EcoWater Systems LLC, under these guarantees, is to replace or repair the component or part which proves to be defective, within the specified time period, and EcoWater is not liable for consequential or incidental damages due to misuse, alteration, neglect, freezing or a force of nature. All implied warranties, including any implied warranty of merchantability or of fitness for a particular purpose, are disclaimed to the extent they extend beyond the above periods. No dealer, agent, representative, or other person is authorized to extend or expand these guarantees.

Some states do not allow limitations on how long an implied warranty lasts or exclusions or limitations of incidental or consequential damage, so the limitations and exclusions in this warranty may not apply to you. This warranty gives you specific legal rights, and you may have other rights which vary from state to state.

SAFETY GUIDES

◆ Read all steps, guides and rules carefully before installing and using the Drinking Water System. Follow all steps exactly to correctly install.

◆ **BE SURE TO FOLLOW APPLICABLE STATE AND LOCAL PLUMBING AND SANITATION CODES** when installing the Drinking Water System. Massachusetts plumbing code 248 CMR shall be adhered to. Please consult your licensed plumber. Using a qualified installer is recommended.

◆ The Drinking Water System works on water pressures of 40 psi minimum, to 100 psi maximum (see the table on Page 4). If house water pressure is over the maximum, install a pressure reducing valve in the water supply line to the Drinking Water System.

◆ This system is acceptable for treatment of influent concentrations of no more than 27 mg/L nitrate and 3 mg/L nitrite measured as N and is certified for nitrate/nitrite reduction only for water supplies with a pressure of 280 kPa (40 psig) or greater. This system is supplied with a nitrate/nitrite test kit. Product water should be monitored periodically according to the instructions provided with the test kit.

◆ **DO NOT** install the Drinking Water System outside, or in extreme hot or cold temperatures. Temperature of the water supply to the Drinking Water System must be between 40°F (minimum) and 100°F (maximum), see the table on Page 4. **DO NOT INSTALL ON HOT WATER.**

◆ Read the other limits (pH, water hardness, etc.), Page 4, and be sure the water supply conforms.

◆ Do not use with water that is microbiologically unsafe or of unknown quality without adequate disinfection before or after the system. Systems certified for cyst reduction may be used on disinfected water that may contain filterable cysts.

◆ This system shall only be used for arsenic reduction on chlorinated water supplies containing detectable residual free chlorine at the system inlet. Water systems using an inline chlorinator should provide a one minute chlorine contact time before the RO system. Conforms to NSF/ANSI 58 for pentavalent arsenic reduction. See performance data sheet and Arsenic Facts section for an explanation of reduction performance.

◆ **NOTE:** This equipment has been tested and found to comply with the limits for a Class B digital device, pursuant to Part 15 of the **FCC** Rules. These limits are designed to provide reasonable protection against harmful interference in a residential installation. This equipment generates, uses, and can radiate radio frequency energy and, if not installed and used in accordance with the instructions may cause harmful interference to radio communications. However, there is no guarantee that interference will not occur in a particular installation. If this equipment does cause harmful interference to radio or television reception, which can be determined by turning the equipment off and on, the user is encouraged to try to correct the interference by one or more of the following measures:

- Reorient or relocate the receiving antenna.
- Increase the separation between the equipment and receiver.
- Connect the equipment into an outlet on a circuit different from that to which the receiver is connected.
- Consult the dealer or an experienced radio/TV technician for help.

Changes or modifications not expressly approved by EcoWater Systems could void the user's authority to operate the equipment.

This device complies with **Industry Canada** Standard RSS-210. Operation is subject to the following two conditions: (1) this device may not cause interference, and (2) this device must accept any interference, including interference that may cause undesired operation of the device.

Ce dispositif est conforme avec la norme CNR-210

d'Industrie Canada. Le fonctionnement du dispositif est sujet aux deux conditions suivantes: (1) le dispositif ne doit pas causer de brouillage, et (2) le dispositif doit accepter tous brouillages, incluant tous brouillages qui peut nuire au bon fonctionnement du dispositif.



European Directive 2002/96/EC requires all electrical and electronic equipment to be disposed of according to Waste Electrical and Electronic Equipment (WEEE) requirements. This directive or similar laws are in place nationally and can vary from region to region. Please refer to your state and local laws for proper disposal of the equipment.

SPECIFICATIONS

Feed water pressure limits - pounds per square inch (psi)	40 - 100
Feed water temperature limits - minimum / maximum degrees F	40 - 100
Maximum total dissolved solids (TDS) - parts per million (ppm)	2000
Maximum water hardness @ 6.9 pH - grains per gallon (gpg)	10
Maximum iron, manganese, hydrogen sulfide	0
Chlorine in water supply	allowable ♦
Feed water pH limits (pH)	4 - 10
Product (quality) water, 24 hours - gallons ● (closed system)	19.7
Percent rejection of TDS, minimum (new membrane) ●	90.8
Automatic shutoff control	yes
Efficiency ■	10.0 %
Recovery □	21.1 %

♦ Chlorine reduction (max. of 2.0 ppm) by the RO Prefilter. **REGULAR MAINTENANCE REQUIRED.** Chlorine will destroy the RO membrane, See page 4.

● Feed water supply at 50 psi, 77°F, and 750 TDS - Quality water production and percent rejection all vary with changes in pressure, temperature and total dissolved solids.

■ Efficiency rating means the percentage of the influent water to the system that is available to the user as reverse osmosis treated water under operating conditions that approximate typical daily use.

□ Recovery rating means the percentage of the influent water to the membrane portion of the system that is available to the user as reverse osmosis treated water when the system is operated without a storage tank or when the storage tank is bypassed.

This system conforms to NSF/ANSI 58 for the specific performance claims as verified and substantiated by test data.

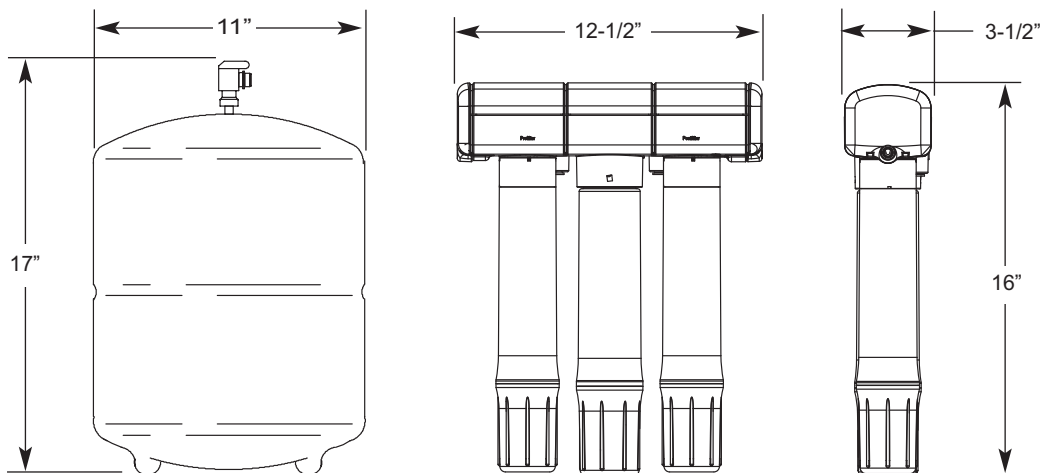

PRETREATMENT OF THE WATER SUPPLY NEEDED TO PREVENT SCALING

TO USE THE CHART...

...Locate the intersecting point of feed **water hardness** and **pH**.

If this point falls within the shaded area, pretreatment* is needed.

*Softening of the water is the suggested pretreatment.

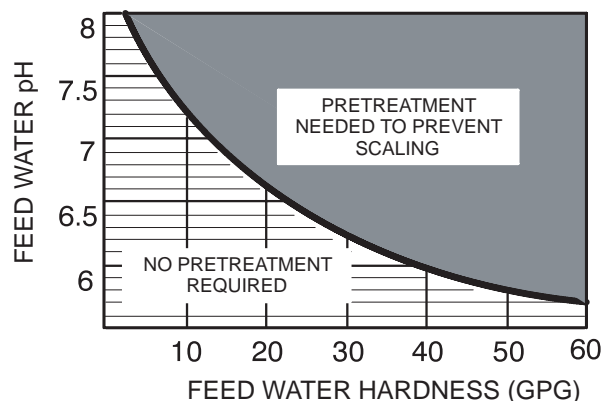

WHAT THE DRINKING WATER SYSTEM WILL DO

The drinking water system is a REVERSE OSMOSIS (RO) water treating unit. Reverse osmosis is a way of reducing dissolved solids and organic matter from water by passing it through a special membrane. The membrane separates minerals and impurities from the water, and they are flushed to the drain. Good tasting, high quality product water goes directly to the drinking water faucet, or to the storage area. The system makes a good supply of drinking water each day (see specifications). How much it will make depends on the feed water supply pressure, temperature, and quality.

Pre and postfilters are replaceable cartridges. The carbon prefilter reduces some chlorine (see specifications) while also filtering sediments. The postfilter reduces any other undesirable tastes and odors before you use the water.

The RO system also includes a standard faucet assembly to vend the drinking water, and a storage tank.

NOTE: A performance data sheet is included listing what the system will reduce from the water supply. See performance data sheet for individual contaminants and reduction performance.

The drinking water system fits under the kitchen or bathroom sink. However, you can install it where most convenient. You do need a COLD water supply pipe and drain point within a few feet (6' tubing lengths included). You can buy longer lengths of tubing if needed to reach more distant points. Be sure tubing is acceptable for use on potable water supplies.

COMPONENTS OF THE SYSTEM

The RO system consists of:

- (1) RO Assembly.
- (2) Color coded tubing.
- (3) Storage Tank.
- (4) Parts bag containing storage tank shutoff valve, drain flow restrictor, mounting washers and screws.
- (5) Hydrolink Plus® RO Module, with batteries and cable, in its own box (Model HERO-375Plus only).
- (6) Faucet, packaged separately.

INSTALLER PROVIDES: (1) fittings to tap the cold water pipe for a feed water source to the RO . . . must adapt to 1/4" tubing; and (2) a drain point for RO discharge water . . . must adapt to 3/8" OD tubing. Both items must comply with state and /or local codes.

Optional fittings are available from EcoWater for use in areas where codes permit.

THINGS TO CHECK BEFORE YOU START TO INSTALL:

★ **FEED WATER** - The water supply to the Drinking Water System must have the qualities listed in the specifications. If not, it will not make product water as it should and life of the RO membrane is shortened. City water most often will have these qualities. Well water may need conditioning. Have the water tested by a water analysis laboratory, and get their recommendations for treatment. Check and comply with local plumbing codes when providing a water supply to the RO. Refer to Pages 22 and 25.

NOTE: Codes in the state of Massachusetts require installation by a licensed plumber, and do not permit the use of the drain clamp. For installation, use plumbing code 248-CMR of the Commonwealth of Massachusetts.

CAUTIONS:

Feed water must have chlorine reduced (prefilters reduce up to amount shown in specifications, Page 4). Chlorine will destroy the RO membrane cartridge. Be sure to service the prefilters, Page 17.

★ **DRAIN POINT** - A suitable drain point (check your local plumbing codes) is needed for reject water from the RO membrane cartridge. Running the RO drain tubing directly to a floor drain, laundry tub, sump, standpipe, etc., is preferred. If that is not possible or practical, using the sink p-trap drain pipe is suggested. A drain clamp (drilling required), or a special drain adapter are available from EcoWater to use where codes permit. Refer to Pages 22 and 25. These options install on the sink drain pipe tailpiece, above the p-trap.

★ **RO FAUCET** - The RO product water faucet installs on the sink, or on the countertop next to the sink. Often, it's installed in an existing sink spray attachment hole. Space is required underneath for tubing to and from the faucet, and for securing it in place. Refer to Pages 7 and 10.

★ **MOUNTING SURFACE** - The RO assembly mounts on a wall surface under the sink, or you can lay it on the bottom of the cabinet. Special washers and screws are included for wall mounting. When the storage tank is full of water, it weighs about 30 pounds. Be sure to set on a surface that will support this weight.

INSTALLATION - FEED WATER SUPPLY

Check and comply with local plumbing codes as you plan, then install a cold feed (supply) water fitting. The fitting must provide a leak tight connection to the RO 1/4" OD tubing, see Figure 6, Page 10. A typical installation, using standard plumbing fittings is shown in Figure 1. A saddle valve (not available from EcoWater) may be used where codes permit. Installation instructions are on Page 22.

NOTE: Codes in the state of Massachusetts require installation by a licensed plumber, and do not permit the use of the drain clamp. For installation, use plumbing code 248-CMR of the Commonwealth of Massachusetts.

PIPE FITTINGS (compression shown)

IMPORTANT: Before starting, close the hot and cold water shutoff valves (See Figure 1). Use a pan to catch water when disassembling the pipe.

Complying with plumbing codes, install a fitting on the kitchen cold water pipe to adapt 1/4" OD tubing. A typical connection is shown in Figure 1. You can use solder or threaded fittings. If threaded fittings are used, be sure to use pipe joint compound or Teflon tape on outside threads.

Do not connect the tubing to the fitting until Step 2, top of Page 10.

FIGURE 1

WATER SUPPLY TYPICAL CONNECTION
(using compression fitting)

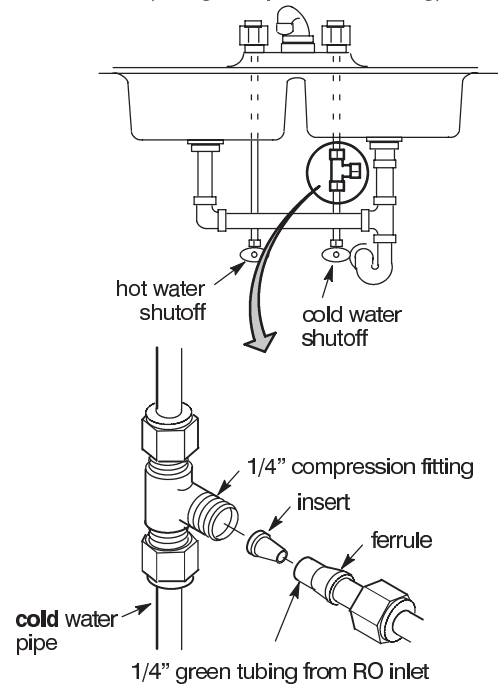

REJECT WATER DRAIN FITTING

Running the RO drain tubing directly to a floor drain, laundry tub, sump, standpipe, etc., is preferred. If that is not possible or practical, check and comply with local plumbing codes as you plan, then install a drain fitting for RO reject water. This fitting is usually installed at the sink p-trap (always above). It must provide a leak-tight connection to 3/8" OD tubing from the RO product water faucet airgap, see Figure 6, Page 10. Typical drain fitting installations are listed below. A drain adapter (part no. 7192230) is available to use where codes permit.

Installation instructions are on Page 22. Other options are shown on Page 25.

"Y" BRANCH TAIL PIECE, OR OTHER APPROVED P-TRAP DRAIN

Reject water from the RO is routed to the RO faucet airgap (1/4" tubing), then to the drain point with 3/8" OD tubing. COMPLYING WITH PLUMBING CODES, install a fitting to accept the 3/8" tubing. Figure 2 shows typical p-trap and "Y" branch tail piece type drains.

Do not connect drain tubing until Step 1, top of Page 10.

FIGURE 2

DRAIN TYPICAL CONNECTION
(check local codes)

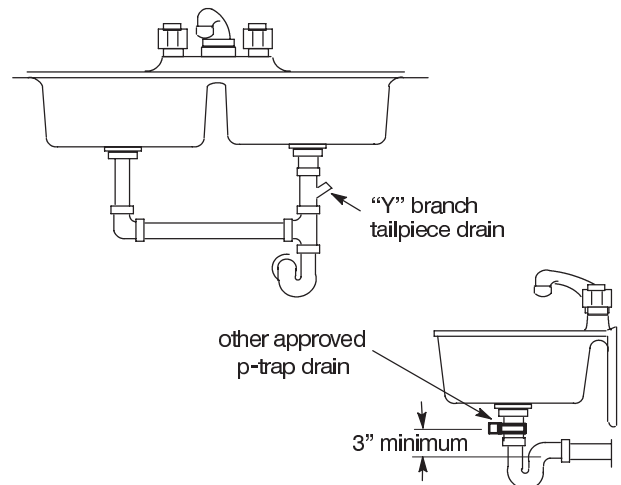

INSTALL THE FAUCET

Select one of the following places to install the faucet. Be sure there's room underneath so you can make the needed connections.

- ◆ In an existing sink spray attachment hole.
- ◆ Drill a hole in the sink top.
- ◆ Drill a hole in the countertop, next to the sink.

NOTE: Looking at Figure 3, be sure the faucet base will fit flat against the surface at the selected location so the o-ring will seal.

1. Do not connect drain tubing until Step 1, top of Page 10.

2. For Model ERO-375, slide the chrome washer onto the faucet stud, Figure 3.

3. For Model ERO-375E or HERO-375Plus, snap the o-ring in the groove on the bottom of the ring and slide the monitor ring onto the faucet stud. The monitor ring LED wire must be routed through the sink or countertop hole and through the spacer, if used, Figure 3.

NOTE: If you will route the RO drain tubing directly to the drain point, disregard Steps 4 and 6 and do Step 1 on top of Page 10.

4. Take the 30" length of 3/8" black tubing and push one end onto the 3/8" faucet barb fitting, Figure 4.

5. Move the RO system into position, under the sink. (Referring to Page 8, hang the system on cabinet wall, or lay on the floor surface, as desired.)

6. Route the 1/4" red tubing from the bottom, up through the faucet mounting hole. Push the end of the tubing onto the 1/4" barb fitting.

7. Work tubing and the faucet stud down, into the mounting hole.

8. On the underside of the sink or countertop, install the spacer (Model ERO-375E or HERO-375Plus only), plastic bushing, flat washer, and hex nut. Slide the large steel washer in place, between the bushing (or spacer) and the bottom of the sink or countertop. Then, tighten the hex nut securely. Make sure that the LED wire is in a position so that it will not be cut, pinched or kinked before tightening the faucet assembly.

9. Thread the tubing connector onto the bottom of the faucet stud.

10. Push the end of the 3/8" blue tubing from the RO, into the tubing connector installed in Step 9.

NOTE: See tubing connection procedures on Page 9. For ease of service and maintenance, keep tubing lengths long enough so removal of the RO system from under the sink is possible.

FIGURE 3 - FAUCET INSTALLATION

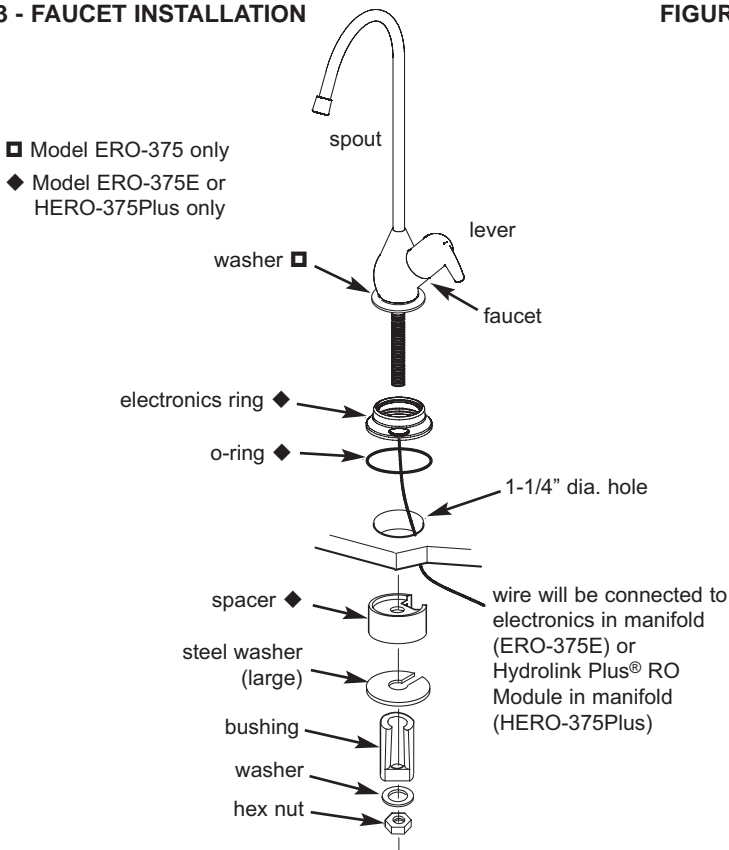
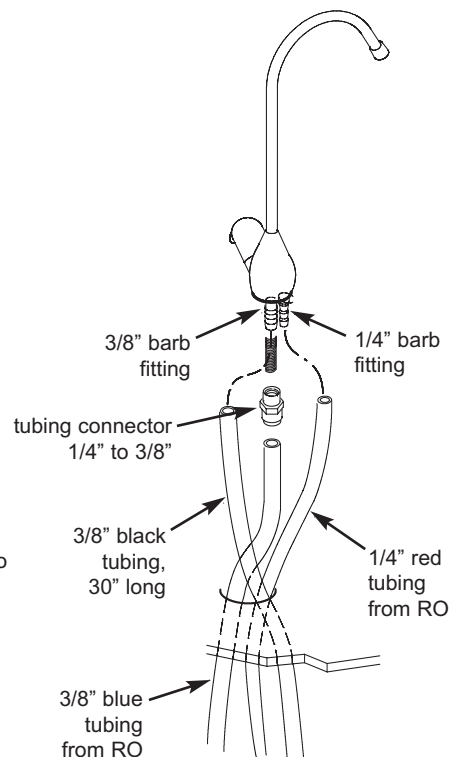

FIGURE 4 - TUBING CONNECTIONS



INSTALL RO ASSEMBLY AND STORAGE TANK

1. Hold the RO assembly up to the wall surface where you will install it. Mark locations for the hanger washers and screws.

2. Fasten the hanger washers to the wall surface. Wood screws are included for fastening to a wood surface. Provide other screws for other surfaces as needed.

3. Hang the RO assembly on the hanger washers.

4. Move the storage tank into place, setting on the floor surface. Use the stand, included with the tank, and position the tank upright, or on its side.

5. Apply teflon tape on the tank nipple threads and install the shutoff valve.

6. Model ERO-375E only: Connect telephone style wire from the monitored faucet to the receptacle on the electronics board, located on the top of the RO unit. Route the wire through the strain relief notch on the back of the manifold.

FIGURE 5

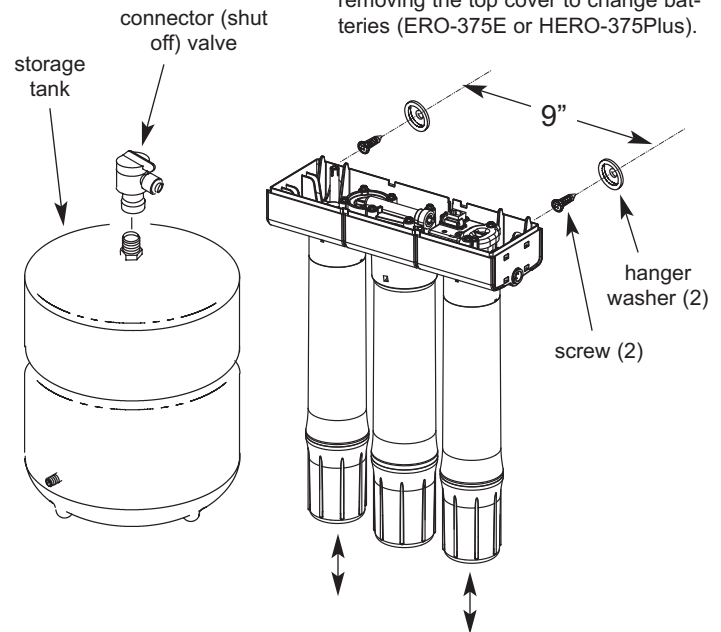

NOTE: Be sure to allow a minimum space of 4" above the system for removing the top cover to change batteries (ERO-375E or HERO-375Plus).

NOTE: Be sure to allow a minimum space of 1-1/2" under the system for removing the cartridges in order to change them.

TUBING CONNECTIONS

HOW TO CUT AND CONNECT THE TUBES

Your Reverse Osmosis Water System includes push-in fittings for quick tubing connection. Review the following instructions before connecting the tubes in the next step.

Cut tubes to length

1. Use a sharp cutter or knife to cut the end of tubing. Always cut the tubing square.

2. Inspect the end (about 1") of the tubing to be sure there are no nicks, scratches or other rough spots. If needed, cut the tubing again.

NOTE: Tubing lengths should allow for the removal of the assembly from the hanger washers for servicing. If tubing lengths are shortened for neater appearance, it may be necessary to keep the assembly on the hanger washers for service.

Connect tubes

1. Push tubing through collet, until it engages the o-ring. Continue pushing until the tube bottoms out against the back of the fitting. A common mistake is to stop pushing when the tube engages the o-ring. This will lead to future leaks. When a 1/4" tube is fully engaged, 11/16" of the tube has entered the fitting. When a 3/8" tube is fully engaged, 3/4" of the tube has entered the fitting.

2. If using tubing other than tubing supplied with the system, be sure it is of high quality, exact size and roundness with a smooth surface.

To Disconnect Tubes

1. Push the collet inward with a finger tip.
2. Continue holding collet inward while pulling the tubing out.

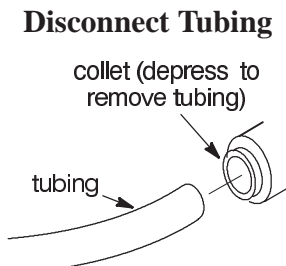

Tube Correctly Cut

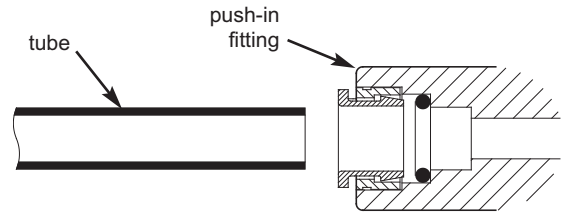

Cut tubing square with end of tubing round, smooth, with no cuts, nicks or flat spots.

Tube Partially Engaged With Fitting

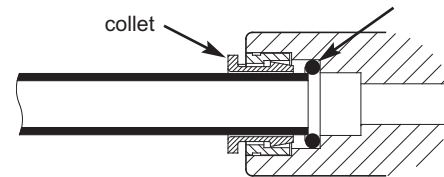

Tube Fully Engaged With Fitting

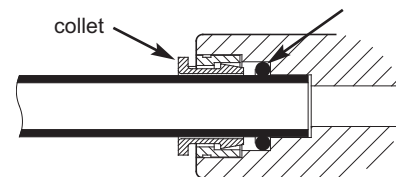

Collet and O-ring

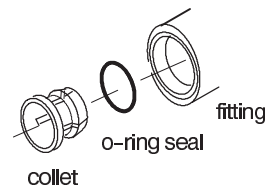

CONNECT WATER SUPPLY, STORAGE TANK AND DRAIN TUBING

1. Connect faucet drain tubing (if using p-trap drain): Route the 3/8" black tubing from the 3/8" faucet barb, to the drain fitting installed on page 6. Keep this tubing run as straight as possible, without loops, dips or low-spots. Cut the tubing as needed and fasten to the drain fitting, securing as required (pages 6 and 22).

Or, connect RO drain tubing (if using floor drain or other approved drain point): Route the 1/4" red tubing from the RO to the floor drain, sump, etc. Be sure to provide an air gap when securing in place.

2. Install Flow Control Insert: Before connecting the 1/4" red tubing to the RO system manifold's drain port, take the flow control insert from the parts bag and insert it into the end of the tube, as shown below.

3. Connect water supply tubing: Route the length of 1/4" green tubing from the RO inlet to the feed water supply fitting, installed on page 6. Connect the tubing as applies (Figures 1 and 6) and tighten the nut securely.

FIGURE 6 - TYPICAL INSTALLATION

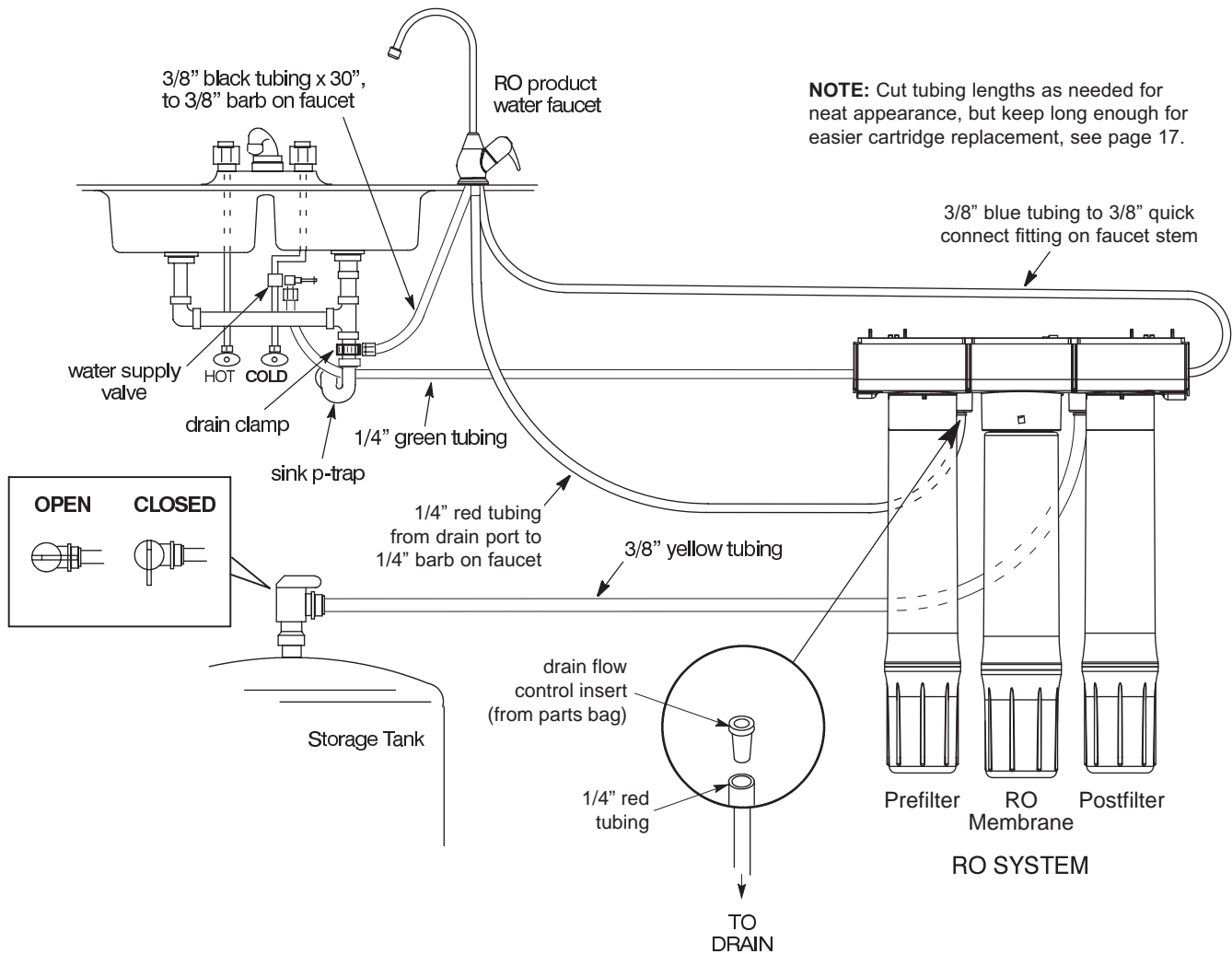

INSTALL THE FILTER CARTRIDGES

1. Remove the plastic wrap from the prefilter, postfilter and RO membrane cartridges.

2. Install the cartridges onto the RO system head assembly, where shown in the figure above. Turn cartridges to the right to tighten.

SANITIZING THE RO SYSTEM

SANITIZE THE SYSTEM

Sanitizing is recommended immediately after installation of the Reverse Osmosis system. It's also recommended after servicing inner parts. It is important that the person installing or servicing the system have clean hands while handling inner parts of the system.

Complete the following steps to sanitize the system.

1. Turn off the water supply to the Reverse Osmosis system, or remove prefilter to automatically shut off water supply.
2. Open the Reverse Osmosis faucet. If the tank is not already empty, allow the water to empty.
3. Use an eyedropper or other suitable tool, and common household bleach (5.25%).

4. Add 3 mL. of bleach into open end of yellow tank tubing. Handle bleach according to bleach manufacturers recommendations.

5. Connect yellow tank tubing to tank connector. Run the length of 3/8" yellow tubing from the RO to the connector (shutoff) valve at the top of the storage tank (Figure 6).

6. Sanitizing the system will be completed during the pressure test and purging steps below.

NOTE: The bleach must be removed from the system before drinking the water. See purging instructions below.

PRESSURE TESTING

DO THE PRECEDING SANITIZING PROCEDURES BEFORE PRESSURE TESTING.

1. Open the water supply shutoff valve to the RO.
2. Open the main water supply valve and several house faucets to purge air from the system. Close faucets when water runs smooth.

3. Open the shutoff valve on the RO water storage tank.

4. In about two hours, pressure will start to build in the RO system. Then, carefully check all fittings and connections for water leaks. Correct leaks if any are found.

PURGING THE SYSTEM

To purge the system, complete the following steps.

1. Open the RO faucet and let water flow through the system for a 24 hour period.



NOTE: Water flow may be a slow trickle at this time.

2. Close the RO faucet after the 24 hour purging period is complete.

3. When the purging is finished, your Reverse Osmosis system is ready for use.

INSTALL THE HYDROLINK PLUS® RO MODULE (Model HERO-375Plus Only)

WIRING CONNECTIONS

1. Locate the cable packed with the Hydrolink Plus® RO Module. One end should be plugged into the telephone-style receptacle identified by the RO icon: 
2. Plug the other end into the RO electronics receptacle on the top the RO manifold assembly (See Figure 7).
3. Locate the the wire from the monitored faucet and plug its connector into the Hydrolink Plus® RO Module receptacle identified by the faucet icon: 

NOTE: When **installing**, or **replacing**, batteries in the Hydrolink Plus® RO module, always make sure that the module's cable is already plugged into the RO manifold electronics receptacle (See Figure 7). If the Hydrolink Plus® module's batteries are installed or changed while this cable is unplugged, and then the cable is plugged into the RO electronics while the Hydrolink Plus® module is starting up (status light flashing), the RO manifold electronics can be permanently damaged.

FIGURE 7

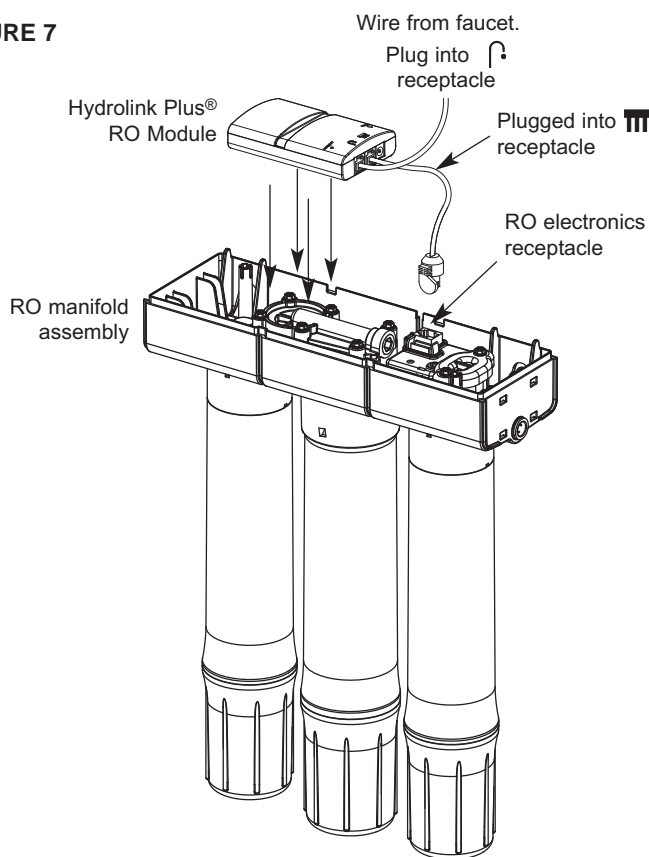

INSTALLING (OR REPLACING) BATTERIES (Model HERO-375Plus Only)

NOTE: Lithium batteries (AAA size) are recommended for maximum battery life.

NOTE: Do not install AAA batteries in the Hydrolink Plus® RO Module if you will be using an external DC supply to power the module.

1. Remove the battery cover from the Hydrolink Plus® RO Module (See Figure 8).
2. Install three (3) AAA size batteries, making sure that they are oriented to match the markings inside the battery compartment.
3. Snap the battery cover back in place.
4. When the batteries are first installed at initial start up, the STATUS light on the Hydrolink Plus® RO Module will flash green once (the LED on the faucet base will also flash green once).

NOTE: Do not install a coin battery in the holder next to the LED (See Figure 9). The coin battery holder is for systems **not** equipped with a Hydrolink® or Hydrolink Plus® RO Module.

FIGURE 8

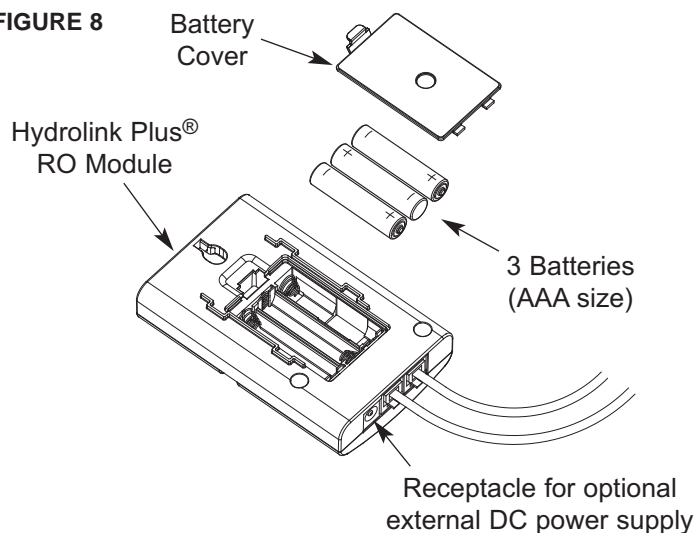
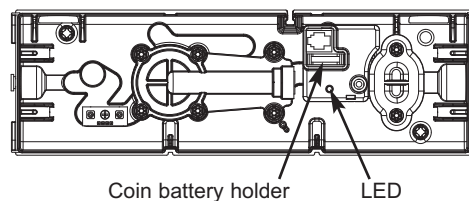

FIGURE 9



CONNECTING THE HYDROLINK PLUS® RO MODULE TO WI-FI (HERO-375Plus Only)

The **CONNECT** button on the Hydrolink Plus® RO module (see Figure 10) is used to:

- Check battery and connection status
- Place unit in Connect Mode ready to connect to Wi-Fi

CHECKING BATTERIES & CONNECTION

To check battery and connection status, press and release the **CONNECT** button (do not hold longer than 1 second). The status is then displayed for 3 seconds by the **STATUS** light (see Figure 10), as follows:

LED Indication	Status
Green for 3 sec.	Batteries are good. The system is connected to the cloud and registered.
Amber for 3 sec.	Batteries are good. The system is registered, but NOT currently connected to the cloud (the last attempt to share data failed).
Alternating Green/Amber	Batteries are good. The system is NOT registered.
Red (3 sec.)	Batteries are low.
No light	Batteries are dead.

CONNECT MODE

To place the Hydrolink Plus® RO module into Connect Mode, ready to connect to Wi-Fi, press and hold for 3 seconds the **CONNECT** button. If battery strength is sufficient to place the unit into Connect Mode, the **STATUS** light begins flashing amber, 1 second on and 1 second off. The unit will remain in Connect Mode for 2 minutes, waiting for you to connect it to the cloud via the home’s wireless router. When a connection has been made, the **STATUS** light turns amber, and it will then turn green after the system has been registered:

LED Indication	Status
Red (3 sec.)	Batteries are too low to place unit into Connect Mode.
Flashing Amber (up to 2 minutes)	System is in Connect Mode, waiting to be connected to the cloud via the home’s wireless router.
Amber after Connect Mode (up to 1 min.)	System successfully connected to the cloud, but is not yet registered.
Green for 1 min. after Connect Mode	System has been successfully connected and registered.
No light after 2 min. in Connect Mode	System not connected to the cloud or registered.

While the unit is in Connect Mode (LED flashing amber), pressing the **CONNECT** button again will not cancel Connect Mode. Also, you will not be able to use the **CONNECT** button during the 1 minute the LED is green following a successful connection and registration.

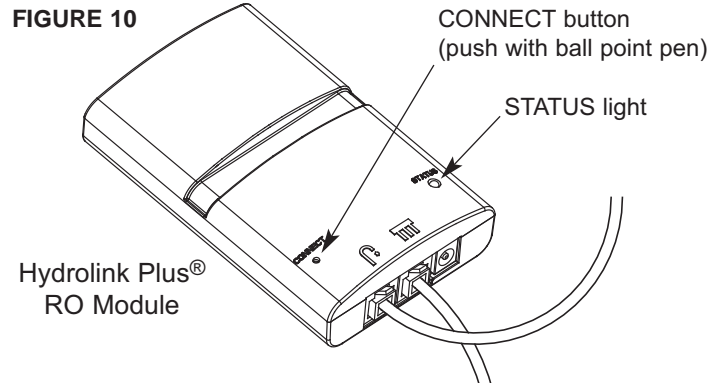

CONNECTING TO WI-FI USING THE APP

1. DETECT DEVICE / CONNECT TO DEVICE

Make sure that you have downloaded the most recent version of the app from your app store: **“EcoWater Systems Wi-Fi Smart Device Manager”** (iOS) or **“EcoWater Systems Wi-Fi Manager”** (Android). Open the app. Place the Hydrolink Plus® RO module into Connect Mode (see previous section). Within 2 minutes, select **“Add a System”** under **“My Devices”**.

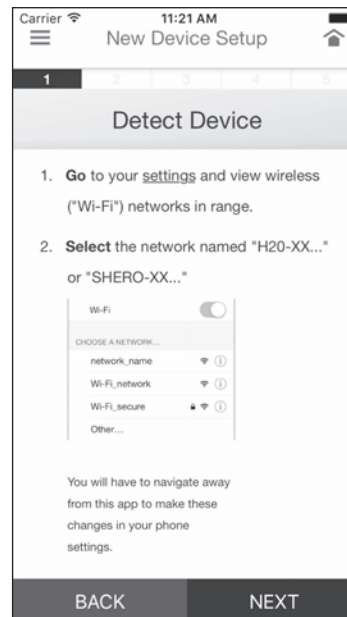

iOS

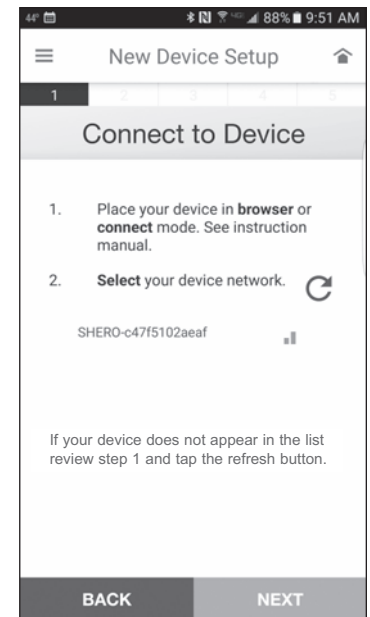

Android

iOS: Go to your “Settings” and display the wireless (Wi-Fi) networks in range. Locate the line beginning with “SHERO” in the list of networks detected. If you do not see “SHERO”, make sure that the Hydrolink Plus® RO Module is in Connect Mode. Select the “SHERO” line and click “NEXT”.

Android: Locate the line beginning with “SHERO” in the list of Wi-Fi devices detected. If you do not see “SHERO”, make sure that the Hydrolink Plus® RO Module is in Connect Mode. Select the “SHERO” line and click “NEXT”.

CONNECTING THE HYDROLINK PLUS® RO MODULE TO WI-FI (HERO-375Plus Only)

2. CONNECT TO NETWORK

Locate the home's wireless network (the one that the Hydrolink Plus® RO module will be using to access the internet) in the list of networks detected. Select that network. Enter the network's security password and click "NEXT".

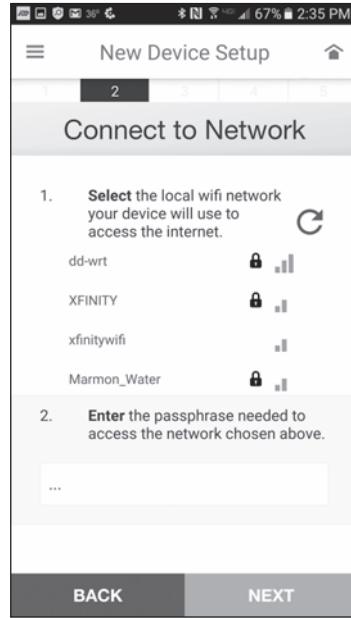

3. REGISTER DEVICE

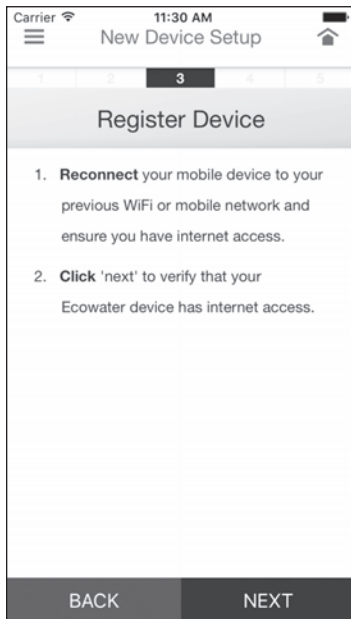

iOS

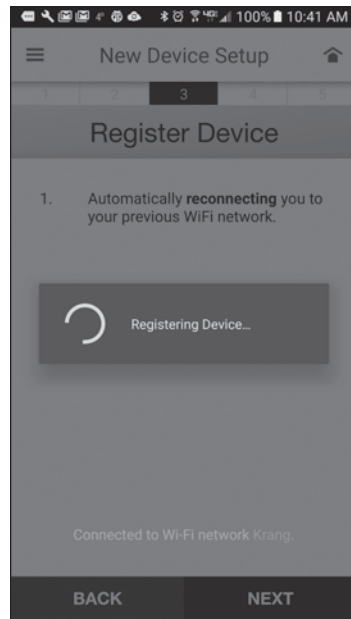

Android

iOS: Go to your "Settings" and display the wireless (Wi-Fi) networks in range. Locate and reconnect to the home's Wi-Fi network. Click "NEXT" and wait while the system automatically:

- Confirms that the Hydrolink Plus® RO Module is connected to the cloud
- Registers the new RO system.

Android: Wait while the system automatically:

- Reconnects to your previous Wi-Fi network
- Confirms that the Hydrolink Plus® RO Module is connected to the cloud
- Registers the new RO system.

4. BASIC SYSTEM SETTINGS

Enter a nickname to identify the RO system, select the desired date format if different from the default, and any other settings displayed in this step. When finished entering basic system settings, click "NEXT".

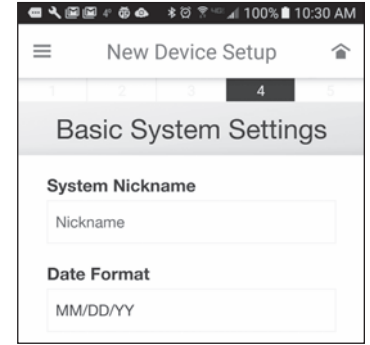

5. SETUP MY ALERTS

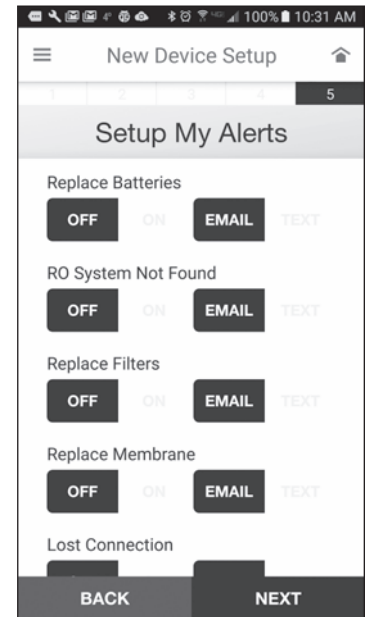
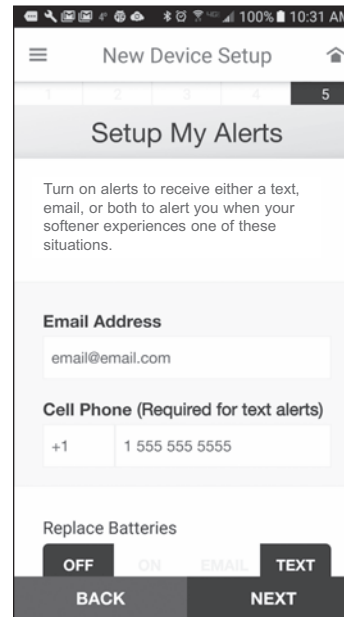

Enter the e-mail address and/or cell phone number (for text messages) where alerts will be sent. Scroll down and select "ON" or "OFF" for each type of alert, as well as whether to send that alert to "EMAIL" or "TEXT". When finished setting up alerts, click "NEXT".

6. DASHBOARD

Following successful completion of the connection procedure, the new RO system's dashboard will be displayed, with the nickname at the top, and various data items displayed.

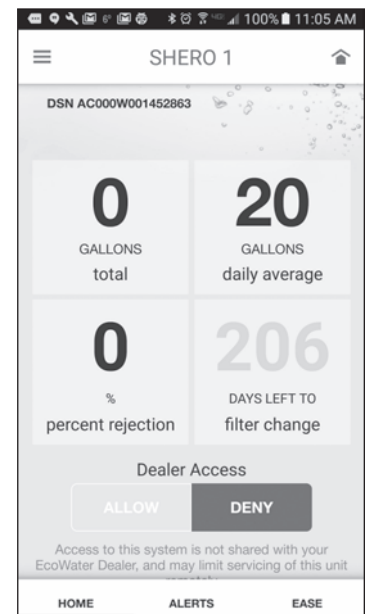

HYDROLINK PLUS® RO MODULE - WI-FI DATA / ALERTS (HERO-375Plus Only)

Once the Hydrolink Plus® RO module has been connected to the cloud and registered on the dealer's web account, a dashboard will be available to display data items from the RO system:

DATA ITEMS (updated daily between 2:00 & 2:59 AM)	
TDS Removal Percentage	Total dissolved solids reduction from inlet to outlet, as a percentage.
Filter Life Remaining (days)	Number of days before the filters should be changed. It will be negative if filter change is overdue.
Dispensed Gallons	Water dispensed through faucet since last filter change, not including water currently stored in tank.
Average Daily Gallons	Daily average water use, in tenths of a gallon.

Additional data items, such as number of days in operation and supply voltage, are shown in the EASE report. Click the EASE tab on the app to view.

To conserve battery life, the Hydrolink Plus® RO module sends updates once a day, between 2:00 AM and 2:59 AM. If a connection can't be made (due to the internet being down, for example), it will try again an hour later.

Click the ALERTS tab on the app to view any alerts.

ALERTS (sent when triggered)	
Replace Batteries	Triggered when batteries are low (see page 13 for replacement instructions)
Replace RO Membrane	Triggered when TDS removal falls below 75% (see pages 17 & 18 for membrane replacement instructions)
Replace Filters	Triggered when filter life reaches zero days (see page 17 for filter replacement instructions)
RO System Not Found	The Hydrolink Plus® module cannot detect the RO manifold electronics (the cable connection is shown in Figure 7 on page 12)

POSITION HYDROLINK PLUS® RO MODULE UNDER RO COVER (HERO-375Plus Only)

1. Place the Hydrolink Plus® RO Module into the RO manifold assembly, where shown in Figures 11 & 12. Route the wire as shown in Figure 12 and carefully push it down into the recesses on the manifold assembly while holding the Hydrolink Plus® RO Module in place.

2. Snap the cover onto the RO manifold assembly, making sure that the Hydrolink Plus® RO Module is lined up as shown in Figure 11.

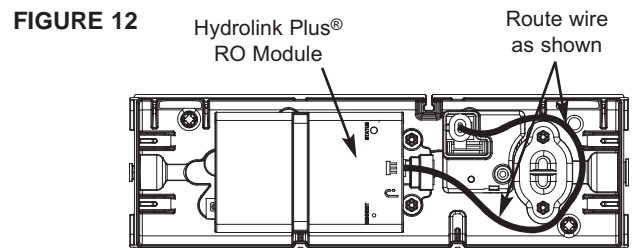
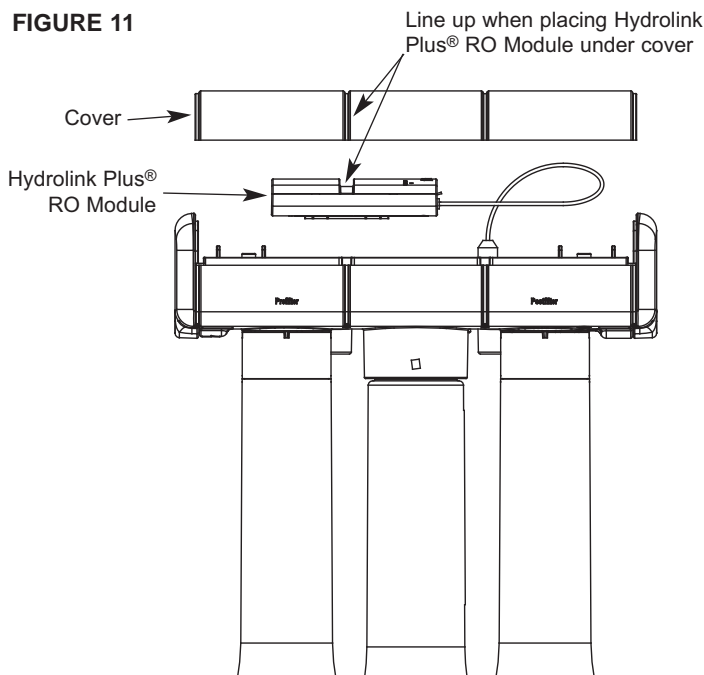

If the Wi-Fi signal (strength displayed in the EASE report) is weak, it may be necessary to mount the module to the wall outside the RO cover (See Figure 13) There is a recess on the back of the module for hanging it vertically from a fastener (not included).

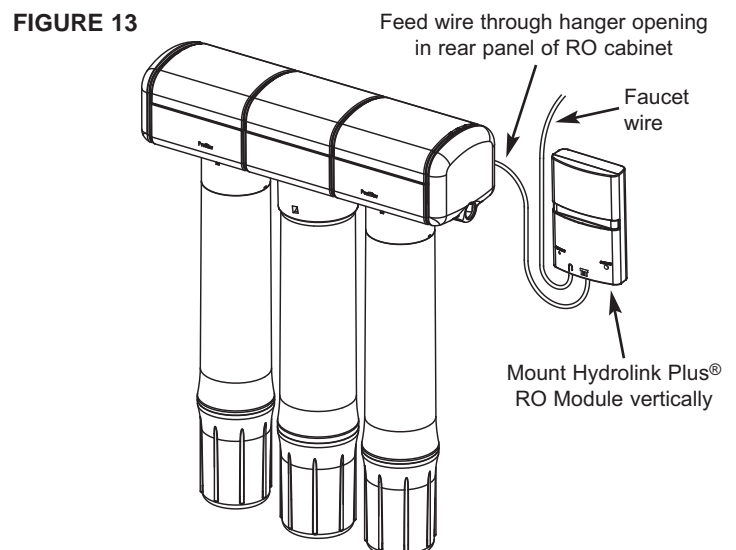

HOW THE RO SYSTEM WORKS

PREFILTER

Water from the cold supply pipe enters the RO assembly sediment prefilter first. The replaceable sediment cartridge reduces chlorine, sand, silt, dirt, other sediments to clean the feed water before entering the RO cartridge and postfilter.

REVERSE OSMOSIS (RO) CARTRIDGE

The cartridge, inside the RO housing, includes a tightly wound, special membrane. Water is forced through the cartridge and the membrane reduces the dissolved solids and organic matter. High quality product water exits the RO housing and goes to the storage tank, or to the post-filter and RO faucet. Reject water, with the dissolved solids and organic matter, is routed through the flow control and to the drain.

STORAGE TANK

The storage tank holds product water. A diaphragm inside the tank keeps water pressurized when the tank is full, to provide fast flow from the RO faucet. The tank is charged with 5-7 psi air.

POSTFILTER

After leaving the storage tank, but before going to the RO faucet, product water goes through the postfilter. The postfilter is an activated carbon type filter. Any remaining tastes, odors and sediments are reduced from the product water. Clean, high quality drinking water is available for use.

FAUCET

The sink or countertop faucet vends the drinking water when opened. It is opened and closed by turning the knob. To comply with plumbing codes, an air-gap is built into the faucet drain water connection.

ELECTRONICS (ERO-375E or HERO-375Plus)

The RO system will monitor the total product flow of the unit and also length of time the filters have been installed. The faucet base has an indicator light that flashes to inform you of the status of the RO membrane and filters.

Green - RO membrane and filters are good.

Amber - Warning, filters need replacing. Filters need replacing, when water has been drawn, after 6 months time (or 650 gallons have been used).

Red - RO membrane needs to be replaced.

When the batteries are first installed at initial start up, the LED indicator light will flash in a red, amber, green

sequence. All timers and counters are reset to zero. In order to reset the time and gallon count feature, push the button on the RO electronics enclosure and hold until the LED flashes, then release.

Model ERO-375E only: the battery needs to be replaced at the time of filter replacement. Use only lithium batteries (CR 2032). Improper placement of battery could damage electronics. Use care when inserting the battery to align it correctly on the PWA with proper polarity.

FIGURE 14

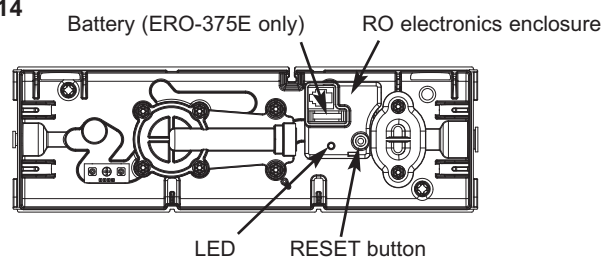
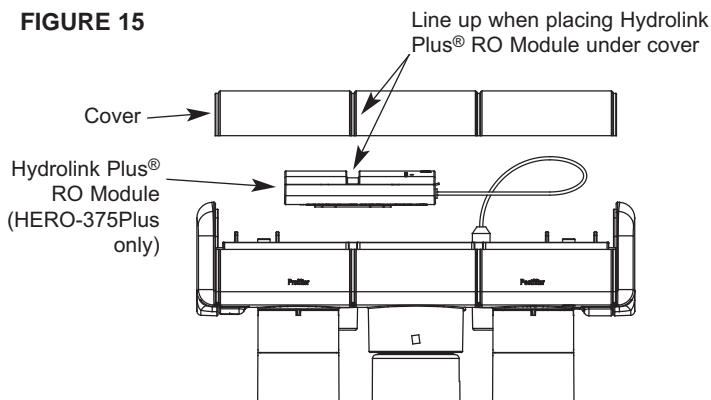

FIGURE 15



SHUTOFF ASSEMBLY

To conserve water, the drinking water system has an automatic shutoff system. When the storage tank has filled to capacity, and the drinking water faucet is closed, pressure closes the shutoff to stop flow into the RO. After drinking water is used, and pressure in the system drops, the shutoff opens to allow water flow again.

CHECK VALVE

A check valve is located in the RO manifold, above the center cartridge. The check valve prevents a backward flow of product water from the storage tank. A backward flow could rupture the RO membrane.

FLOW CONTROL

Water flow through the RO membrane is regulated by the flow control. It maintains the desired flow rate to obtain the highest quality drinking water. The flow control is located in the 1/4" red drain tube. A small cone-shaped screen fits over the end of the flow control to help prevent plugging with drain water sediments.

CARE OF YOUR REVERSE OSMOSIS SYSTEM

To keep your reverse osmosis system operating and producing high quality water, you must make sure supply water is always within the limits shown in the specifications. Good supply water helps to assure longer life from the RO membrane cartridge, prefilter and postfilter cartridges. However, each of these will wear out in time and need replacement.

This reverse osmosis system contains a replaceable treatment component critical for effective reduction of total dissolved solids. The monitor faucet feature provides continuous analysis of the systems performance. For systems not equipped with the monitor faucet function, it is highly recommended that you have your water tested at least every 6 months to verify your system is performing properly. Test kits are available by calling 1-800-949-8220, or check the water testing section of your local phone directory.

If the RO assembly is wall mounted, you may be able to replace parts with the assembly left on the wall. If not, simply lift the RO assembly from the mounting washers and lay on the cabinet floor when replacing the prefilter and post filter cartridges and RO membrane.

PREFILTER AND POST FILTER CARTRIDGES

You must replace the prefilter cartridge often to protect the RO membrane from being destroyed by chlorine, and/or from plugging with sediments in your water supply. If the water supply contains both chlorine and sediments, replace the prefilter cartridge at least every 6 months of product water use. Replace more often than 6 months if it begins to plug with sediments.

If the water has sediments only, with no chlorine, you may notice a slower making of product water as the prefilter collects the sediments. When this occurs, replace the prefilter cartridge. Also replace the post filter cartridge.

To replace the filter cartridges, see Figure 16:

1. Remove (turn to the left) the prefilter cartridge from the filter head.
2. Remove the postfilter cartridge (turn to the left) the postfilter cartridge from the filter head.
3. Discard both cartridges in a proper manner.
4. Insert new cartridges, starting with the post filter, turning to the right to reattach the cartridges.
5. Model ERO-375E only: replace the battery with new (CR 2032 or equivalent).
6. On the ERO-375E or HERO-375Plus, press and hold the button on the RO electronics enclosure until the green light begins flashing. Release the button during the 3 seconds that the light flashes.
7. It is recommended to discard the first full tank after the filters have been changed to minimize carbon fines.

RO MEMBRANE CARTRIDGE

This reverse osmosis system contains a replaceable component critical to the efficiency of the system. Replacement of the reverse osmosis component should be one with identical specifications, as defined by the manufacturer, to assure the same efficiency and contaminant reduction performance.

The life of the RO membrane cartridge depends mostly on the pH and hardness of the supply water to the RO system (see specifications). Cartridge life is shorter with higher pH. For example, if supply water pH is from 6.8 to 7.7, the cartridge may last for well over one year. However, cartridge life may be as short as 6 months if the pH is as high as 8.5 to 10. Higher pH weakens the cartridge membrane and causes pin-hole leaks.

It's time to replace the RO cartridge when the red LED

continued on next page

FIGURE 16

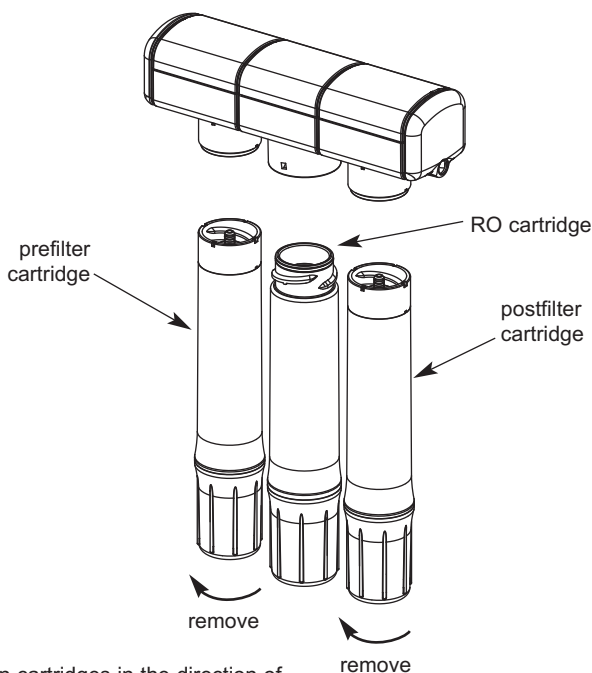

Turn cartridges in the direction of the arrow to remove. Turn them in the opposite direction to install.

CARE OF YOUR REVERSE OSMOSIS SYSTEM

continued from previous page

flashes or the production rate and/or quality of product water drops. Product water may begin to taste different or bad, indicating solids and organics are passing through the RO membrane. When replacing the RO cartridge, replace the prefilter and postfilter cartridges as well.

To replace the RO cartridge (see Figure 16):

1. Remove (turn to the left) the pre filter cartridge from the filter head to relieve pressure on the Reverse Osmosis cartridge.

2. Remove the RO cartridge.

3. Remove the post filter cartridge.

4. Discard the cartridges in a proper manner.

5. Install new cartridges in reverse order (post filter, Reverse Osmosis and then prefilter). Turn cartridges to the right to re-attach to the filter heads.

6. Model ERO-375E only: replace the battery with new (CR 2032 or equivalent).

7. On the ERO-375E or HERO-375Plus, press and hold the button on the RO electronics enclosure until the green light begins flashing. Release the button during the 3 seconds that the light flashes.

8. Purge the RO membrane cartridge following instructions on Page 11.

FLOW CONTROL

The flow control is vital for proper operation of the RO membrane cartridge. The control keeps water flow through the membrane at the needed rate to obtain the best quality product water.

Periodically check the flow control to be sure the small hole through it is clean and unrestricted.

AUTOMATIC SHUTOFF / PADDLEWHEEL SERVICE

If either the shutoff assembly or paddlewheel requires service, be sure to reassemble parts exactly as shown below.

FIGURE 18

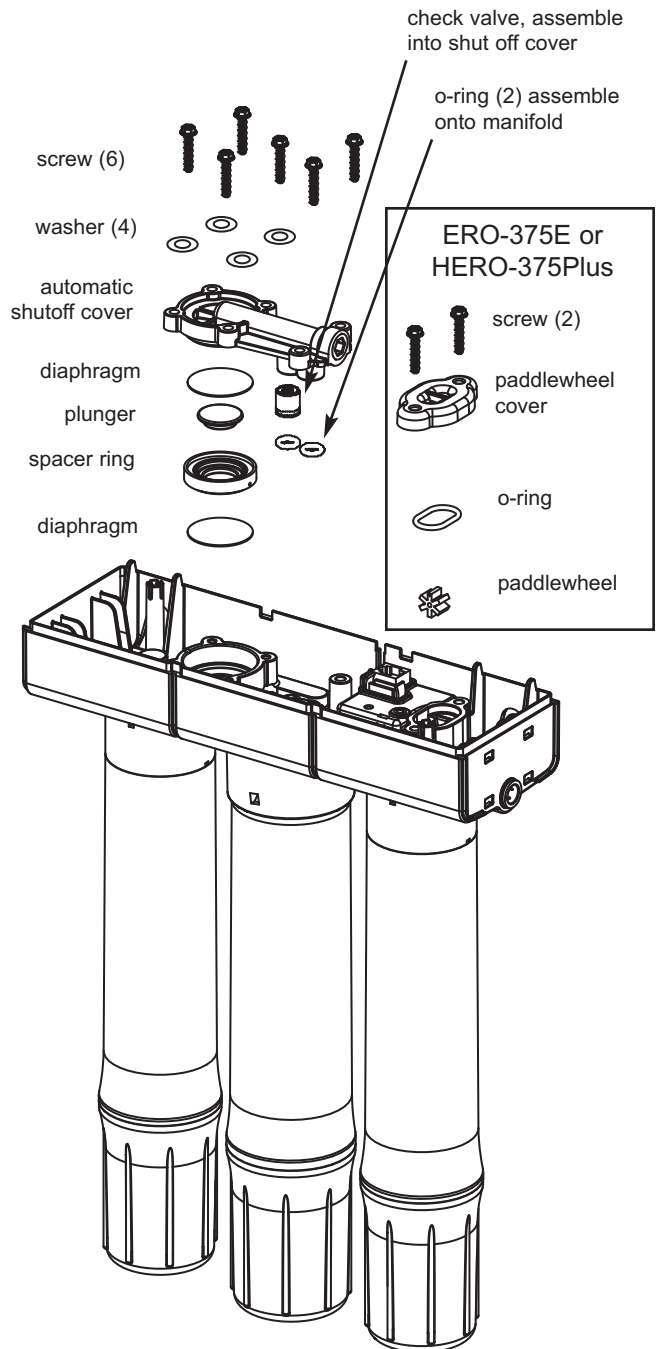
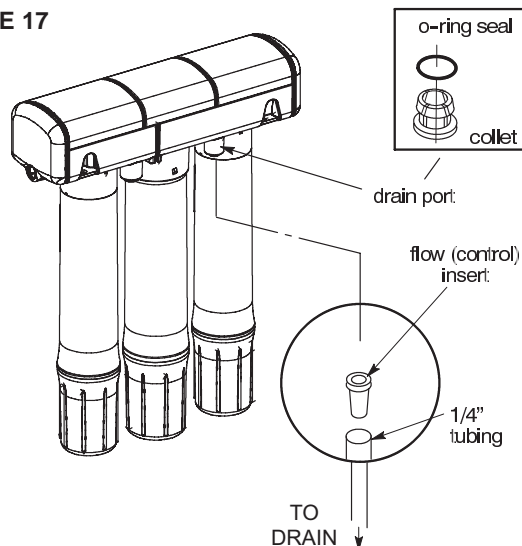

FIGURE 17



CARE OF YOUR REVERSE OSMOSIS SYSTEM

FILTER CHANGE ALERT LED (ERO-375E or HERO-375Plus)

The ERO375E and HERO-375Plus provide the option of alerting you to the need for a filter change at either 6 or 12 month intervals. The timer is factory set to 6 months. The recommended interval is 6 months, but certain water conditions may allow a 12 month setting. Consult a water professional to determine the proper interval.

NOTE: Please read the following 3 steps and study the order of events in the table at right before starting.

1. Remove the top cover and locate the RESET button on the PWA board.

2. To change from 6 to 12 months, press and continue
FIGURE 19

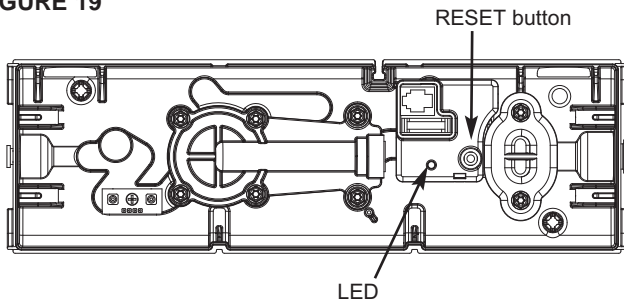

to hold down the RESET button. **Watch the LED during this process.** The LED will go on steady, then flicker, then go off for 6 seconds (See chart at right). When the LED begins to blink (after button has been held down for about 12 seconds), immediately release the button.

3. Once the button is released, the LED will show several double blinks to indicate that the timer has been set to 12 months.

To change back to 6 months:

To change the unit back to 6 months, repeat the sequence, holding down the RESET button for 12-15 seconds, until the light begins to blink. Once the button is released, the light will show several single blinks to indicate that the timer has been set to 6 months.

Order	RESET Button	LED
1	-	● OFF
2	Press & Hold	○ ON (Steady)
3	Continue Holding	⊃○⊂ Flicker
4	Continue Holding	● OFF (for 6 sec.)
5	Release Now	⊃○⊂ Single Blink or Double Blink
6	-	⊃○⊂ Double Blink (set for 12 mo.) or Single Blink (set for 6 mo.)
7	-	● OFF

CARE OF YOUR REVERSE OSMOSIS SYSTEM

REVERSE OSMOSIS SYSTEM CARE GUIDE MODEL NOs. ERO-375, ERO-375E & HERO-375Plus

1. AT LEAST every 6 months, replace the prefilter and postfilter cartridges or when faucet LED flashes yellow or Wi-Fi alert indicates "Replace filters".
2. Replace the RO membrane cartridge when the percent rejection of total dissolved solids (TDS) is less than shown in the specifications (see **B**, below) or when faucet LED flashes red or Wi-Fi alert indicates "Replace membrane".
3. Replace the batteries once per year or when Wi-Fi alert indicates "Replace batteries".

If any of the following occur before the 6 months, replace as directed.

A. Slow Making of Product Water: Replace the prefilter cartridge. If the production rate does not improve, replace the post filter cartridge and RO membrane cartridge.	C. Chlorine Taste and/or Odor: Replace the prefilter, post filter and RO membrane cartridges.
B. High Total Dissolved Solids (TDS) in Product Water: If water quality is in question, contact your local dealer for testing. It is important to test both the treated and untreated water to determine system performance. If the TDS is not within the system's performance guidelines, replace the pre-filter, post filter and RO membrane cartridges.	

OTHER TROUBLESHOOTING

PROBLEM	CAUSE	CORRECTION
Chlorine taste and/or odor in the RO product water.	The amount of chlorine in your water supply exceeds maximum limits, and has destroyed the RO membrane.	If the water supply contains more than 2.0 ppm of chlorine, additional filtering of the water supply to the RO is needed. Correct this condition before doing maintenance on the RO system. Replace the prefilter, post filter and RO membrane cartridges.
	The prefilter is no longer removing chlorine from the water supply.	
Other taste and/or odor.	Post filter expended.	Replace the post filter cartridge. If taste and odor persists, replace the prefilter cartridge and RO membrane cartridge.
	RO membrane cartridge expended.	
	Contamination in product water storage.	Use sanitizing procedures. Replace the post filter cartridge.
System makes product water too slowly.	Water supply to the RO system not within specifications.	Increase water pressure, precondition the water, etc., as needed to conform before doing maintenance on the RO system.
	Prefilter or RO membrane cartridges plugged with sediments or fouled.	Replace the prefilter cartridge. If rate does not increase, replace the postfilter cartridge and RO membrane cartridge.
	Flow Control Insert plugged.	Check and clean Flow Control Insert.
System makes lower amount of product water than usual.	Storage tank air-charge less than 5 - 7 psi.	Open RO faucet and drain tank until flow slows to a drip. Keep faucet open and check tank pressure. If low, pressurize to 6 psi. Close faucet to refill the tank.
High total dissolved solids (TDS) in product water - flashing red LED.	Water supply to the RO system not within specifications.	Increase water pressure, precondition the water, etc., as needed to conform before doing maintenance on the RO system.
	RO membrane cartridge expended.	Replace the prefilter, postfilter and RO membrane cartridges, flow control, and screen.
Water leaking from faucet airgap hole.	Drain side of faucet airgap (3/8" tubing) plugged, restricted, or incorrectly connected to drain point.	Inspect and eliminate restriction or plug. Refer to installation instructions for proper drain connection.
Continual water flow to drain.	Check valve or automatic shutoff assembly plugged, restricted or parts worn.	Clean, repair or replace as needed.
Faucet LED indicator light does not function after battery change.	Battery dead.	Replace with new battery.
	Battery installed incorrectly.	Install battery correctly.
Continual high water flow to drain and no product water.	Missing flow restrictor in red drain tube or its corresponding port.	Replace flow restrictor.

REVERSE OSMOSIS SCHEMATIC

FIGURE 20

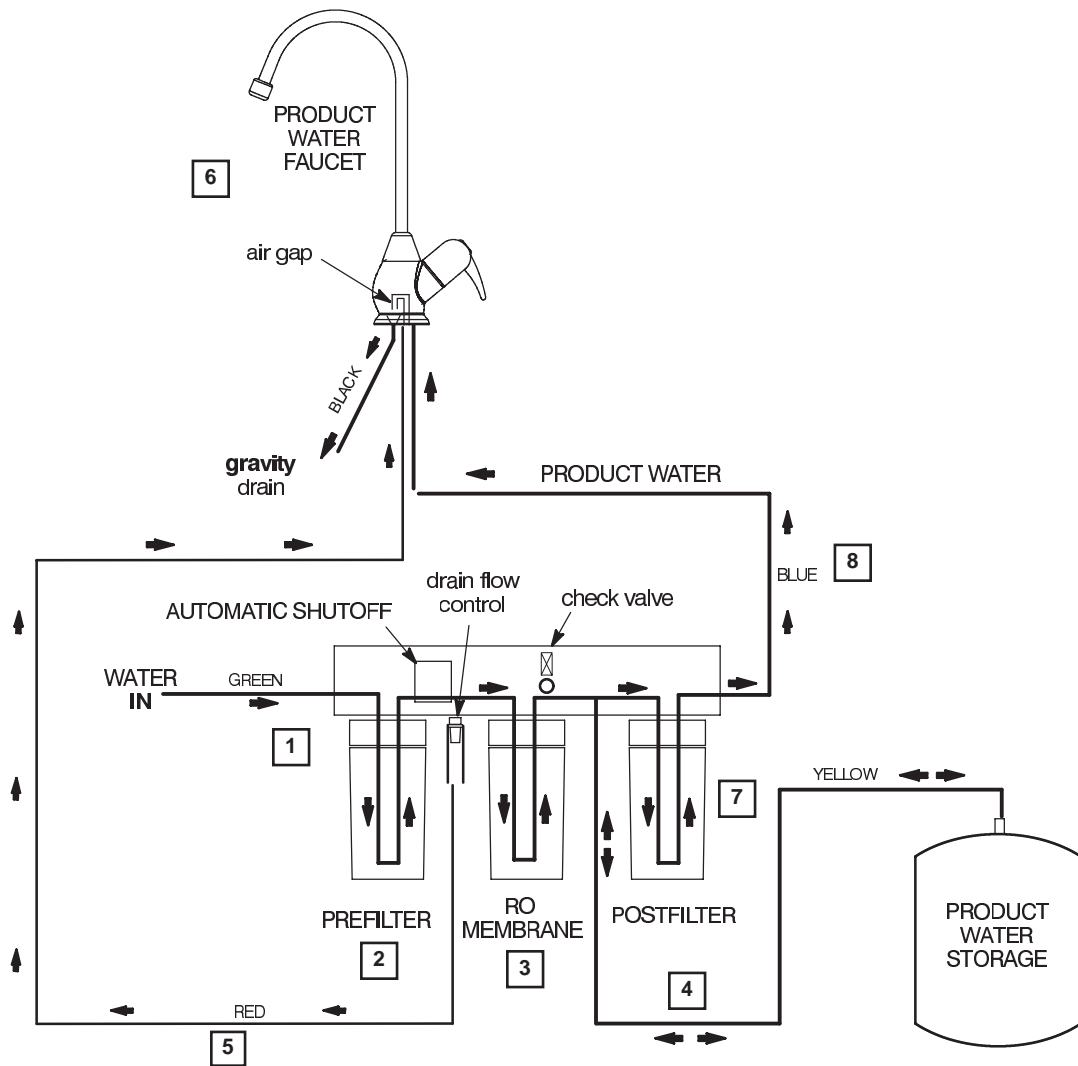

Water Flow Description

1. Water enters prefilter. Sand, silt and other sediments are reduced. Chlorine is also reduced.
2. Water leaves prefilter and proceeds to the Reverse Osmosis Cartridge.
3. Water enters the Reverse Osmosis membrane. Dissolved solids are reduced.
4. Processed water leaves the Reverse Osmosis Membrane and flows to the storage tank.
5. Waste water with dissolved solids leave the Reverse Osmosis membrane and flows to the drain.
6. Faucet is activated.
7. Processed water leaves the storage tank and flows to the post filter filtered to ensure fresh taste.
8. Water flows to the Reverse Osmosis faucet.

INSTALLATION OF OPTIONAL FITTINGS (not included)

SADDLE VALVE, not available from EcoWater

NOTE: This type of valve pierces a hole in copper tubing or plastic pipe. If installing on iron pipe, you have to drill a 1/8" pilot hole for the piercing pin. Be sure to turn off water to the pipe and to drain water from it before drilling. READ THE FOLLOWING DANGER NOTE.

DANGER (IF DRILLING METAL PIPE): To protect yourself from serious injury or fatal shock, use a battery powered hand drill only to make the hole. Do not use an electric drill.

1. Looking at Figure 21, turn the valve into clamp X and tighten (may be preassembled). Turn the valve handle all the way out.
2. Place the seal on the inside of clamp X as shown. Be sure the piercing pin does not stick out beyond the seal.
3. Place clamp X and Z around the pipe and secure in place with two screws. Tighten both screws evenly, but do not overtighten. Clamp Z will either have threaded screw holes, or two nuts are included.
4. Carefully turn the handle inward to pierce a hole in the copper or plastic pipe.

DRAIN ADAPTER, part no. 7192230

- The optional drain adapter installs in the sink drain pipe, always above or ahead of the p-trap. Be sure to comply with your local plumbing codes. Other drain pipe fittings, in addition to the adapter, may be needed.
- The drain adapter fits 1-1/2" sink drain pipe.
- The adapter installs directly onto the sink tailpiece as typically shown in Figure 21.
- Locate so drain tubing from the faucet makes a straight run to the adapter, without dips, loops, low spots or kinks.

NOTE: Consult a plumber if you are not familiar with plumbing procedures.

1. Use a ferrule and nut to assemble the drain tubing connector to the drain adapter. Turn the connector to about 45° from the 12:00 position, as shown (to 10:00 or 2:00 position as needed). Tighten the nut securely.
2. Carefully disassemble the sink drain pipe and clean the tailpiece to assure a leak-tight fit.

3. Install the drain adapter onto the sink tailpiece, using a ferrule and nut. Snug the nut, but do not tighten.
4. Assemble the p-trap to the drain adapter, and other drain pipe fittings as required (check codes) to complete the drain run.
5. Tighten all connections, but do not overtighten and break plastic fittings.

FIGURE 21

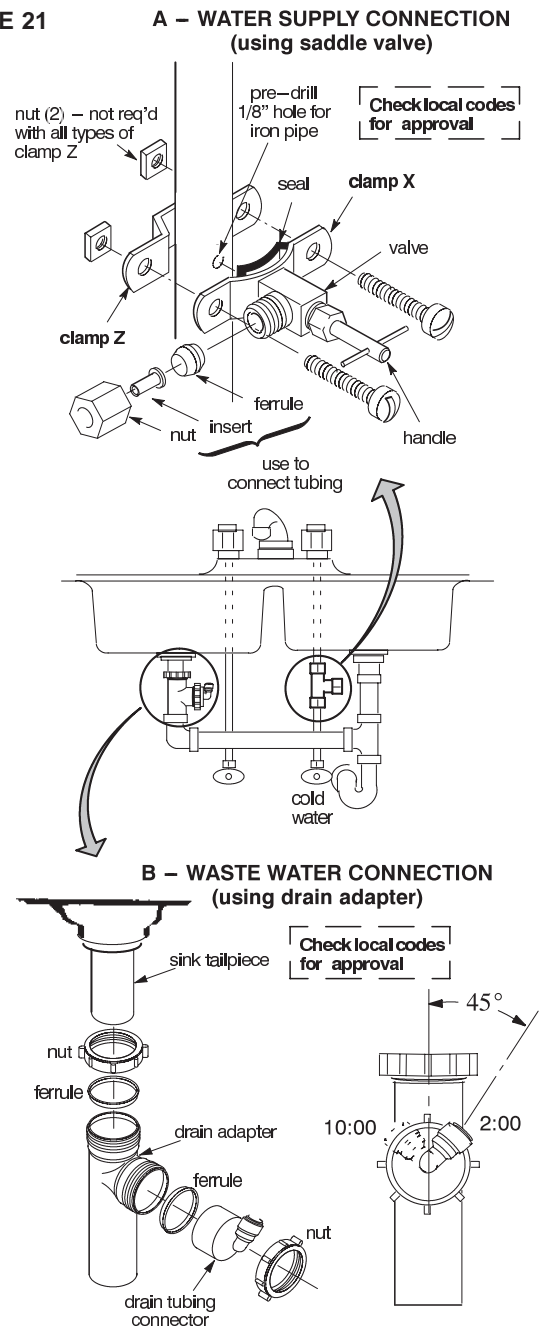

NOTE: Codes in the state of Massachusetts require installation by a licensed plumber, and do not permit the use of a saddle valve. For installation, use plumbing code 248-CMR of the Commonwealth of Massachusetts.

REMOTE LOCATION FOR REVERSE OSMOSIS SYSTEM

Possible remote locations for the RO nearby the kitchen or bathroom sink include;

- (1) a basement area underneath the sink, and
- (2) an adjacent room or closet.

Longer lengths of tubing (see parts list) and telephone cable extension (purchase locally*) may be needed.

You can run the drain tubing directly to one of several suitable open drain points, as shown below, bypassing the faucet airgap and p-trap drain. This type of drain is the preferred over the p-trap drain adapter. Check your local codes. Always be sure to provide an air gap between the end of the hose and the drain point of 2 pipe diameters or 1 inch, whichever is larger.

*Telephone cable extension must consist of a male connector on one end and a female connector on the other to keep proper polarity. Polarity may be reversed if a coupler is used and monitor will not work.

FIGURE 22

Note: Tubing colors as supplied with RO system.

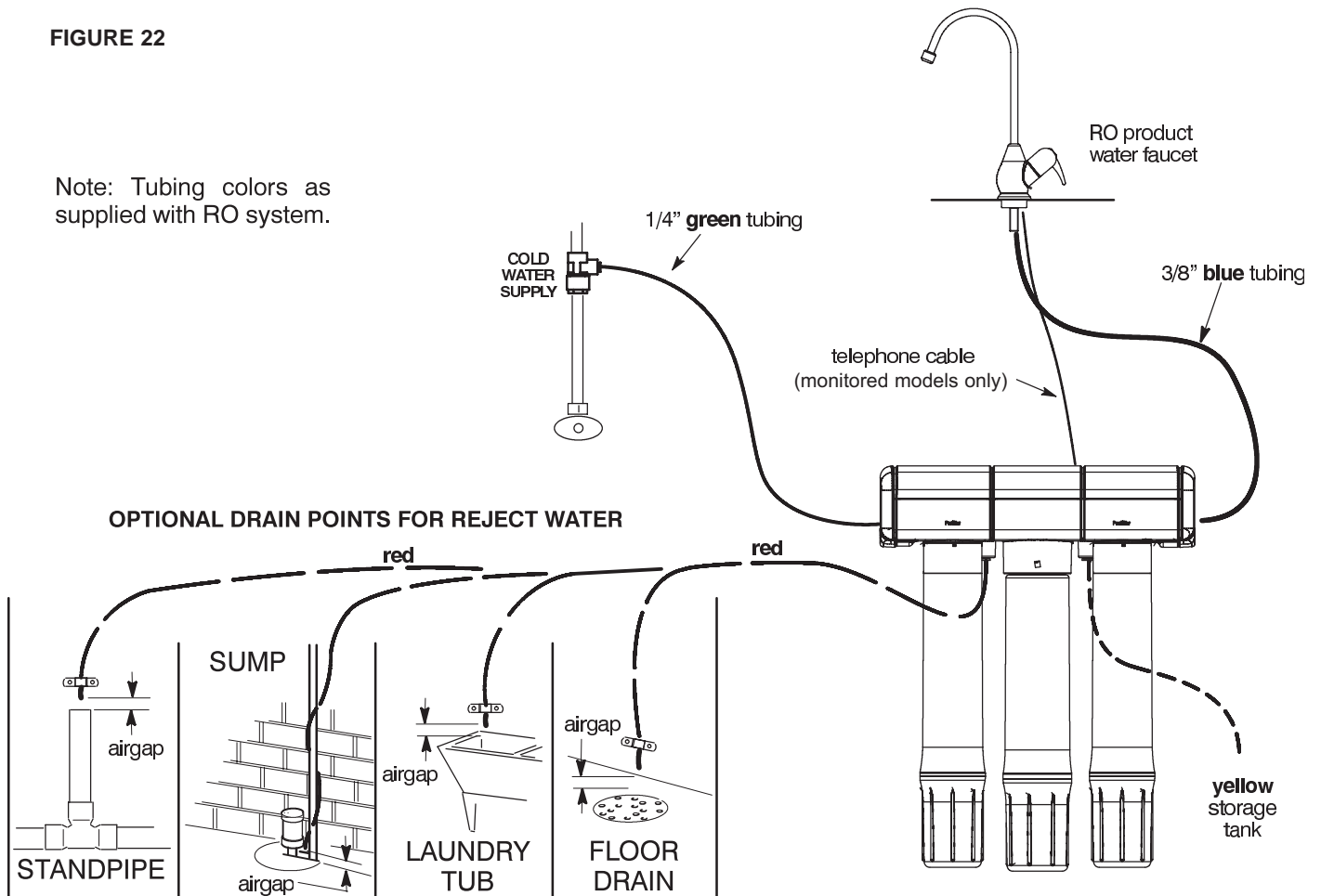

REPAIR PARTS

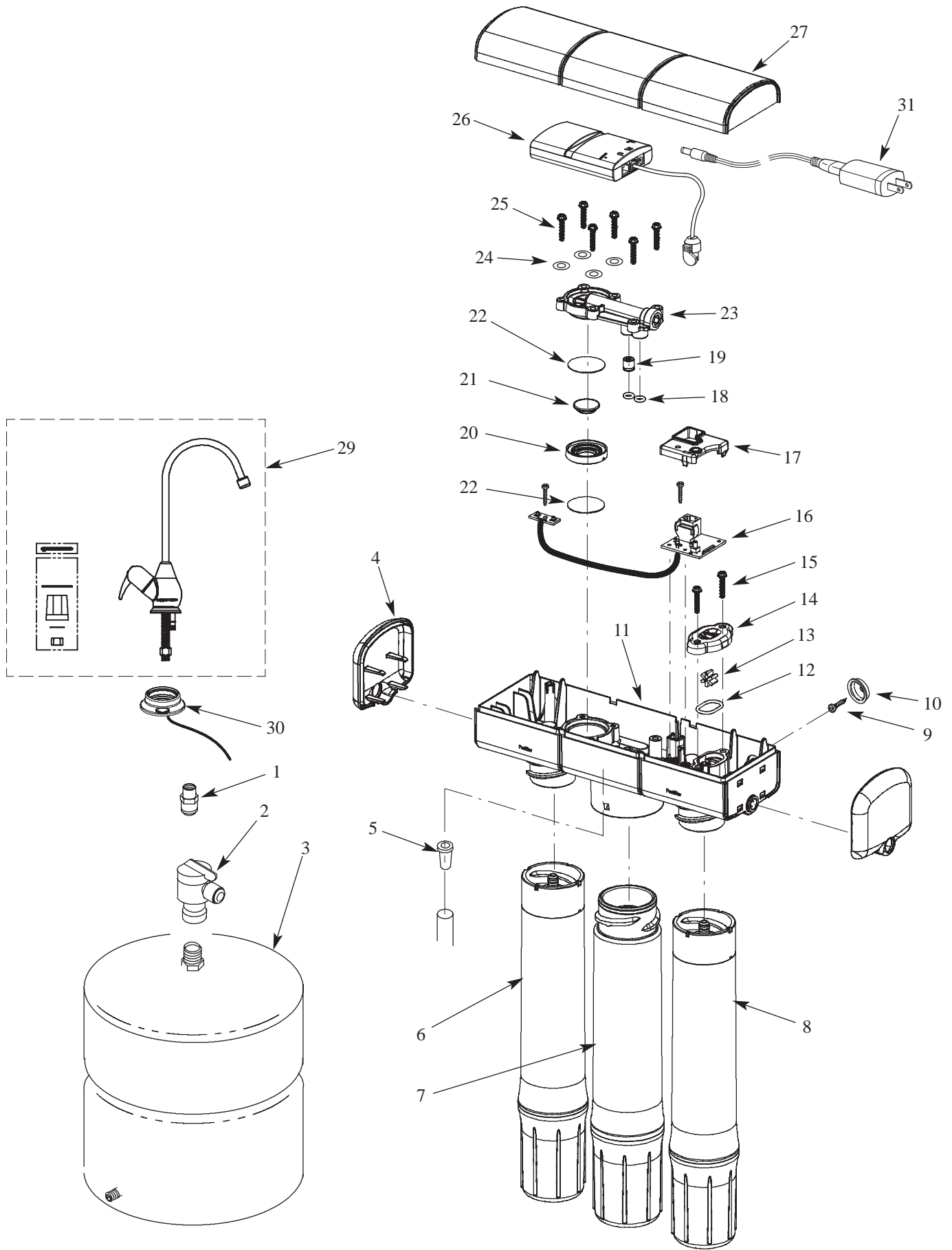

REPAIR PARTS

Key No.	Part No.	Description
1	7207920	Connector, 7/16-24 x 3/8 Q.C. Tube
2	7251034	Connector, 1/4 NPT x 3/8 Q.C. Tube
3	7256018	Storage Tank
4	7273379	End Cap (2 req'd)
■	7095030	Cone Screen
5	7199486	Flow Control Insert
6	7278913	Pre Filter Cartridge, CTO
	7273484	Pre Filter Cartridge, Sediment ❖
7	7278905	RO Membrane Cartridge, 50 gpd
	7273264	RO Membrane Cartridge, 75 gpd ❖
8	7278913	Post Filter Cartridge, CTO
	7273183	Post Filter Cartridge, VOC ❖
-	7333129	Mounting Hardware Kit (includes 2 ea. of Key Nos. 9 & 10)
9	↑	Screw (2 req'd)
10	↑	Hanger Washer (2 req'd)
11	7285376	Manifold Assembly, ERO-375E or HERO-375Plus (includes Key Nos. 12-25, assembled)
	7285384	Manifold Assembly, ERO-375 (includes Key Nos. 18-25, assembled)
-	7333200	Paddlewheel Kit, ERO-375E or HERO-375Plus (includes Key Nos. 12-15)
12	↑	O-Ring, Paddlewheel
13	↑	Paddlewheel
14	↑	Cover, Paddlewheel
15	↑	Screw (2 req'd)
16	7280156	Rep'l Electronic Board (PWA), including screws, ERO-375E or HERO-375Plus
-	7333195	PWA Kit (includes Key No. 17 & decal)
17	↑	Cover, PWA, ERO-375E or HERO-375Plus
■	↑	Decal, PWA Cover, ERO-375E or HERO-375Plus

Key No.	Part No.	Description
-	7333137	Check Valve Kit (includes Key No. 19 & 2 of Key No. 18)
18	↑	O-Ring, Auto. Shutoff Cover (2 req'd)
19	↑	Check Assembly
-	7333179	Diaphragm Kit (includes Key Nos. 20, 21 & 2 of Key No. 22)
20	↑	Spacer Ring
21	↑	Plunger
22	↑	Diaphragm (2 req'd)
-	7333145	Automatic Shutoff Kit (includes Key No. 23, 4 of Key No. 24 & 6 of Key No. 25)
23	↑	Automatic Shutoff Cover Assembly
24	↑	Washer (4 req'd)
25	↑	Screw (6 req'd)
26	7360663	Hydrolink Plus® RO Module, with batteries & cable, HERO-375Plus only
27	7272763	Cover
■	7314183	Battery, CR 2032 or eq., ERO-375E only
FAUCET OPTIONS (packaged separately)		
29	7272959	Faucet, Chrome
	7277187	Faucet, Brushed Nickel
30	7261500	Electronic Monitor Kit, Chrome, ERO-375E or HERO-375Plus
	7278230	Electronic Monitor Kit, Brushed Nickel, ERO-375E or HERO-375Plus
OPTIONAL ACCESSORIES and TUBING		
31	7363417	Power Supply, 5V DC, with cable, ❖ for Hydrolink Plus® RO Module
32	119-8600084	Water Supply Fitting, 1/4" Q.C. ❖
33	7208489	Drain Adaptor ❖
34	7079791	Drain Clamp ❖
■	7301203	Sanitization Kit ❖
■	7161823	Tubing, 1/4" x 20' - white ❖ ●
■	7157280	Tubing, 3/8" x 20' - white ❖ ●

■ Not illustrated.

❖ Not included.

● Tubing lengths for remote location installations and for direct replacement for colored lengths of tubing.

To order parts call your local EcoWater dealer or go to www.ecowater.com to locate a dealer in your area.

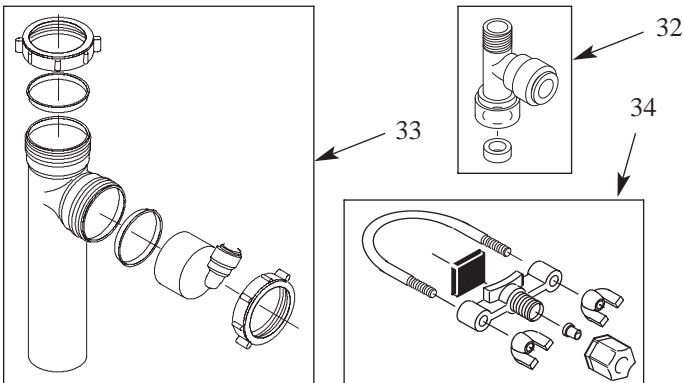

PERFORMANCE DATA

Reverse Osmosis Filter Systems - Models ERO-375-CP, ERO-375-BN, ERO-375-WH, ERO-375-BK, ERO-375-RB, ERO-375E-CP, ERO-375E-BN, ERO-375E-WH, ERO-375E-BK, ERO-375E-RB, HERO-375-CP, HERO-375-BN, HERO-375-WH, HERO-375-BK, HERO-375-RB, and HERO-375Plus

IMPORTANT NOTICE: Read this performance data and compare the capabilities of these units with your actual water treatment needs. It is recommended that, before purchasing a water treatment unit, you have your water supply tested to determine your actual water treatment needs. These filter systems are designed to be used for the reduction of the substances listed below. Do not use where water is microbiologically unsafe or of unknown quality, without adequate disinfection before or after the systems. Systems certified for cyst reduction may be used on disinfected water that may contain filterable cysts. These systems are acceptable for treatment of influent concentrations of no more than 27 mg/L nitrate and 3 mg/L nitrite in combination measured as N and are certified for nitrate/nitrite reduction only for water supplies with a pressure of 280 kPa (40 psig) or greater. These systems have been tested for the treatment of water containing pentavalent arsenic (also known as As (V), As (+5), or arsenate) at concentrations of 0.30 mg/L or less. These systems reduce pentavalent arsenic, but may not reduce other forms of arsenic. These systems shall be used on water supplies containing a detectable free chlorine residual at the system inlet or on water supplies that have been demonstrated to contain only pentavalent arsenic. Treatment with chloramine (combined chlorine) is not sufficient to ensure complete conversion of trivalent arsenic to pentavalent arsenic. Please see the Arsenic Facts section on page 28 for further information. While testing was performed under standard laboratory conditions, actual performance of these systems may vary based on local water conditions. These systems have been tested and shown to operate at their calculated recovery rating under standard test conditions. Some or all of the contaminants reduced by this unit may not be in your water supply. See elsewhere in this owner's manual for further instructions on filter replacement, system installation, operating procedures, and warranty. The maintenance instructions must be followed for the product to perform as indicated below.

General Information

These products are undercounter systems that filter and store quality drinking water ready for use. They contain a carbon sediment filter, RO membrane, and an activated carbon post filter. The electronics for Models ERO-375E-CP, ERO-375E-BN, ERO-375E-WH, ERO-375E-BK, ERO-375E-RB, HERO-375-CP, HERO-375-BN, HERO-375-WH, HERO-375-BK, HERO-375-RB, and HERO-375Plus, serve three sensing and monitoring functions. A flashing green light means the RO system is producing high quality drinking water. The red light flashing indicates the RO cartridge, flow control, and screen need to be replaced. When the amber light flashes, 6 months time or 750 gallons have passed through the unit, requiring that the pre filter and post filter cartridges be replaced. These systems have been tested according to NSF/ANSI 58 for reduction of substances listed below. The concentration of the indicated substances in water entering the systems was reduced to a concentration less than or equal to the permissible limit for water leaving the system, as specified in NSF/ANSI 58. The testing was performed using spiked chlorine free deionized water with ≤ 1 NTU turbidity, 7.5 ± 0.5 pH, $25 \pm 1^\circ\text{C}$, and $1\mu\text{S/cm}$ conductivity.

Maintenance

Replacement filter prices may vary. The approximate price for replacement pre filter and post filter, part number 7278913, is \$30 to \$60 per carbon element filter. The approximate price for the R.O. membrane, part number 7278905, for all models is \$125 to \$175, plus applicable taxes, shipping, and labor

Application Specifications for Feed Water

Pressure	40-100 psig (2.8-7.0 kg/cm ²)
Temperature.....	40-100°F (5-38°C)
Maximum TDS Level.....	2000 mg/L
Maximum Hardness @ 6.9 pH	10 gpg ¹ (171 mg/L)
Maximum Iron, Manganese, Hydrogen Sulfide.....	0 mg/L
Maximum Chlorine	2.0 mg/L ²
pH Range	4-10

¹ Grains per gallon.

² A carbon prefilter is part of this system to protect the reverse osmosis membrane from deterioration should there be chlorine in the supply water. This reverse osmosis system contains a replaceable treatment component critical for effective reduction of TDS. The product water shall be tested periodically to verify that the system is performing satisfactorily.

PERFORMANCE DATA

PERFORMANCE CLAIMS

ERO-375-CP, ERO-375-BN, ERO-375-WH, ERO-375-BK, ERO-375-RB, ERO-375E-CP, ERO-375E-BN, ERO-375E-WH, ERO-375E-BK, ERO-375E-RB, HERO-375-CP, HERO-375-BN, HERO-375-WH, HERO-375-BK, HERO-375-RB & HERO-375Plus

Substance	NSF Required Influent Challenge Concentration (mg/L) ¹	NSF Max. Permissible Product Water Concentration (mg/L) ¹	Average Influent (mg/L) ¹	Avg. / Max. Effluent (mg/L) ¹	Avg. / Min. Percent Reduction
Arsenic (pentavalent) ²	0.30 ±10%	0.010	0.320	0.006 / 0.011	98.2 / 96.6
Barium ²	10 ±10%	2.0	10	0.23 / 0.58	97.8 / 94.4
Cadmium ²	0.03 ±10%	0.005	0.028	0.0005 / 0.0012	98.1 / 95.7
Chromium (VI) ²	0.3 ±10%	0.1	0.310	0.009 / 0.017	97.0 / 94.4
Chromium (III) ²	0.3 ±10%	0.1	0.310	0.005 / 0.007	98.3 / 97.7
Copper ²	3.0 ±10%	1.3	2.9	0.03 / 0.07	98.8 / 97.8
Cysts ²	≥50,000 #/mL ⁴	99.95% ³	160,000 #/mL ⁴	2 / 11 #/mL ⁴	>99.99 / >99.99
Fluoride	8.0 ±10%	1.5	8.4	0.3 / 0.4	96.5 / 95.2
Lead ²	0.15 ±10%	0.010	0.16	0.001 / 0.003	99.1 / 98.1
Nitrate plus Nitrite (as N) ²	30 ±10%	10.0	29	8.7 / 11	69.7 / 60.7
Nitrate (as N) ²	27.0 ±10%	10	26	8.0 / 9.8	69.0 / 60.8
Nitrite (as N) ²	3.0 ±10%	1.0	3.1	0.72 / 0.95	77.2 / 70.8
Radium 226/228 ²	25 pCi/L ⁵ ±10%	5 pCi/L ⁵	25 pCi/L ⁵	5 / 5 pCi/L ⁵	80 / 80 pCi/L ⁵
Selenium ²	0.10 ±10%	0.05	0.10	0.002 / 0.003	98.0 / 97.0
Turbidity ²	11 ±1 NTU ⁶	0.5 NTU ⁶	11 NTU ⁶	0.1 / 0.2 NTU ⁶	99.0 / 98.3
TDS ²	750 ±10%	187	760	60 / 70	92.1 / 90.8
Chlorine Taste & Odor	2.0 ±10%	1.0	1.9	0.09 / 0.19	95.2 / 90.5
Ammonium ⁷	1.2 ±10%	1.0 ⁸	2.5	0.24	90
Bicarbonate ⁷	300 ±10%	100 ⁸	280	10	96
Bromide ⁷	1.5 ±10%	3.3 ⁸	11	1.3	89
Chloride ⁷	800 ±10%	250 ⁸	770	60	92
Magnesium ⁷	30 ±10%	10 ⁸	31	<1.0	97
Sodium ⁷	350 ±10%	117 ⁸	340	40	88
Sulfate ⁷	800 ±10%	250 ⁸	780	12	98
Tannin ⁷	3.0 ±10%	1.0 ⁸	2.9	0.1	97
Zinc ⁷	15 ±10%	5.0 ⁸	15	0.25	98

Daily Production Rate: 19.75 gal./day (74.76 liters/day)²

Efficiency Rating: 10.01%⁹

Recovery Rating: 21.17%¹⁰

¹ Milligrams per liter, which is equivalent to parts per million (PPM).

² Tested by NSF International according to NSF/ANSI Standard 58.

³ NSF minimum percent reduction requirement. Acceptance level for this substance is based on percent reduction, rather than maximum effluent concentration.

⁴ Particles per milliliter.

⁵ Pico Curies per liter.

⁶ Nephelometric Turbidity Units.

⁷ Tested by Spectrum Labs, a qualified independent laboratory, against accepted industry protocol.

⁸ There is no maximum permissible effluent concentration for this substance because it is not included in the chemical reduction claims listed in NSF Standard 58. The maximum effluent concentrations listed were established by Spectrum Labs and are based on one third of the target influent.

⁹ Efficiency rating means the percentage of the influent water to the system that is available to the user as reverse osmosis treated water under operating conditions that approximate daily usage.

¹⁰ Recovery rating means the percentage of the influent water to the membrane portion of the system that is available to the user as reverse osmosis treated water when the system is operated without a storage tank or when the storage tank is by-passed.

PERFORMANCE DATA

Perfluorochemical (PFC) Removal*			
Substance	Influent (µg/L)**	Effluent (µg/L)**	Percent Reduction
Perfluorooctanoic acid (PFOA)	3	<0.2	93.3
Perfluorooctane sulfonate (PFOS)	3	<0.2	93.3
Perfluorobutanoic acid (PFBA)	10	<0.2	98

* Tested by Minnesota Department of Health.

** Micrograms per liter, which is equivalent to parts per billion (PPB).

ARSENIC FACTS

Background: Arsenic (abbreviated As) can occur naturally in well water. There are two forms of arsenic: pentavalent arsenic [also called As (V), As (+5), and arsenate] and trivalent arsenic [also called As (III), As (+3), and arsenite]. Although both forms are potentially harmful to human health, trivalent arsenic is considered more harmful than pentavalent arsenic. In well water, arsenic may be pentavalent, trivalent, or a combination of both. Additional information about arsenic in water can be found on the Internet at the U.S. Environmental Protection Agency (USEPA) website: www.epa.gov/safewater/arsenic.html.

Testing Your Water: Arsenic in water has no color, taste or odor. It must be measured by a lab test. Public water utilities must have their water tested for arsenic. You can get the results from your water utility. If you have your own well, you can have the water tested. The local health department or the state environmental health agency can provide a list of certified labs. The cost is typically \$15 to \$30.

Pentavalent vs. Trivalent Arsenic Removal: These systems are very effective at reducing pentavalent arsenic from drinking water. These models were tested in a lab and proven to reduce 300 parts per billion (ppb) pentavalent arsenic to below 10 ppb, the USEPA standard for safe drinking water.

RO systems are not as effective at reducing trivalent arsenic from water. These models will not convert trivalent arsenic to pentavalent arsenic. If you have free chlorine residual in contact with your water supply for at least one minute any trivalent arsenic will be converted to pentavalent arsenic and reduced by this RO. Other water treatment chemicals such as ozone, and potassium permanganate will also change trivalent arsenic to pentavalent arsenic. A combined chlorine residual (also called chloramine) may not convert all the trivalent arsenic. If you get your water from a public water utility, contact the utility to find out if free chlorine or combined chlorine is used in the water system.

Maintenance: It is strongly recommended that you follow the maintenance instructions and have your water tested periodically to make sure the system is performing properly. See replacement element information above for recommendations on maintaining your Reverse Osmosis drinking water treatment system.



FOR IOWA USE ONLY

All sales in Iowa require the following signature before consummation of sale. These signatures must be retained by seller/renter for 2 years minimum.

Buyer/Renter _____ Date _____

Seller _____ Date _____

Seller's Address _____

Seller's Phone No. _____

Product: EcoWater Systems 375 Series Reverse Osmosis Filter System (model numbers are shown in the box at right)

EcoWater Systems LLC
P.O. Box 64420
St. Paul, MN 55164
www.ecowater.com



Models ERO-375-CP, ERO-375-BN, ERO-375-WH, ERO-375-BK, ERO-375-RB, ERO-375E-CP, ERO-375E-BN, ERO-375E-WH, ERO-375E-BK, ERO-375E-RB, HERO-375-CP, HERO-375-BN, HERO-375-WH, HERO-375-BK, HERO-375-RB, and HERO-375Plus have been tested and certified by NSF International against NSF/ANSI Standard 42 for the reduction of chlorine, taste and odor, Standard 58 for the reduction of arsenic, barium, cadmium, chromium (hexavalent), chromium (trivalent), copper, cysts, lead, nitrate (as N), nitrite (as N), radium 226/228, selenium, turbidity and TDS.