



Undersink
REVERSE OSMOSIS
DRINKING WATER SYSTEM

A Marmon Water/Berkshire Hathaway Company

ERO-175

- ◆ Safety Guides
 - ◆ Installation
 - ◆ Operation
 - ◆ Maintenance
 - ◆ Repair Parts

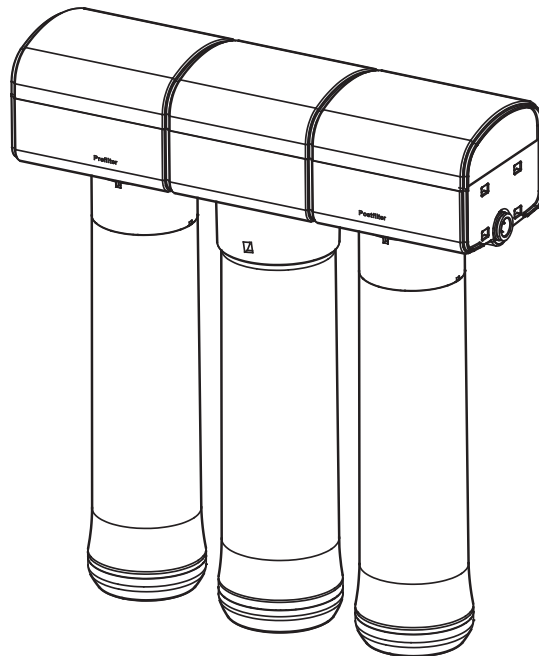

EcoWater Systems LLC
P.O. Box 64420
St. Paul, MN 55164
TEL (651) 739-5330

System tested and certified by
NSF International against
NSF/ANSI Standards 42 & 58. See
performance data sheet for details.



7308077 (Rev. J 5/11/12)

TABLE OF CONTENTS

Specifications	3	Tubing Connections.	8
What the Drinking Water System will do	4	Connect Water Supply, Storage Tank	
Components of the system	4	& Drain Tubing	9
Checks to make before installing	4	Sanitizing / Pressure Testing.	10
Installing	5-8	How the Drinking Water System works.	11
Feed Water Supply.	5	Care of your Reverse Osmosis System.	12-14
Reject Water Drain Fitting.	5	Installation of Optional Fittings	16
Installing Faucet	6	Remote Installation.	17
Installing RO Asm & Storage Tank.	7	Repair Parts	18-19
		Warranty	20

SAFETY GUIDES

- ◆ Read all steps, guides and rules carefully before installing and using the Drinking Water System. Follow all steps exactly to correctly install.
- ◆ **BE SURE TO FOLLOW APPLICABLE STATE AND LOCAL PLUMBING AND SANITATION CODES** when installing the Drinking Water System. Massachusetts plumbing code 248 CMR shall be adhered to. Please consult your licensed plumber. Using a qualified installer is recommended.
- ◆ The Drinking Water System works on water pressures of 40 psi minimum, to 100 psi maximum (see the table on page 3). If house water pressure is over the maximum, install a pressure reducing valve in the water supply line to the Drinking Water System.
- ◆ This system is acceptable for treatment of influent concentrations of no more than 27 mg/L nitrate and 3 mg/L nitrite measured as N and is certified for nitrate/nitrite reduction only for water supplies with a pressure of 280 kPa (40 psig) or greater. This system is supplied with a nitrate/nitrite test kit. Product water should be monitored periodically according to the instructions provided with the test kit.
- ◆ **DO NOT** install the Drinking Water System outside, or in extreme hot or cold temperatures. Temperature of the water supply to the Drinking Water System must be between 40°F (minimum) and 100°F (maximum), see the table on page 3. **DO NOT INSTALL ON HOT WATER.**
- ◆ Read the other limits (pH, water hardness, etc.), page 3, and be sure the water supply conforms.
- ◆ Do not use with water that is microbiologically unsafe or of unknown quality without adequate disinfection before or after the system. Systems certified for cyst reduction may be used on disinfected water that may contain filterable cysts.
- ◆ This system shall only be used for arsenic reduction on chlorinated water supplies containing detectable residual free chlorine at the system inlet. Water systems using an inline chlorinator should provide a one minute chlorine contact time before the RO system. Conforms to NSF/ANSI 58 for pentavalent arsenic reduction. See performance data sheet and Arsenic Facts section for an explanation of reduction performance.

SPECIFICATIONS

Feed water pressure limits - pounds per square inch (psi)	40 - 100
Feed water temperature limits - minimum / maximum degrees F	40 - 100
Maximum total dissolved solids (TDS) - parts per million (ppm)	2000
Maximum water hardness @ 6.9 pH - grains per gallon (gpg)	10
Maximum iron, manganese, hydrogen sulfide	0
Chlorine in water supply	allowable ♦
Feed water pH limits (pH)	4 - 10
Product (quality) water, 24 hours - gallons ● (closed system)	18.4
Percent rejection of TDS, minimum (new membrane) ●	86.5
Automatic shutoff control	yes
Efficiency ■	12.2 %
Recovery □	22.9 %

♦ Chlorine reduction (max. of 2.0 ppm) by the RO Prefilter. **REGULAR MAINTENANCE REQUIRED.** Chlorine will destroy the RO membrane, See page 4.

● Feed water supply at 50 psi, 77°F, and 750 TDS - Quality water production and percent rejection all vary with changes in pressure, temperature and total dissolved solids.

■ Efficiency rating means the percentage of the influent water to the system that is available to the user as reverse osmosis treated water under operating conditions that approximate typical daily use.

□ Recovery rating means the percentage of the influent water to the membrane portion of the system that is available to the user as reverse osmosis treated water when the system is operated without a storage tank or when the storage tank is bypassed.

This system conforms to NSF/ANSI 58 for the specific performance claims as verified and substantiated by test data.

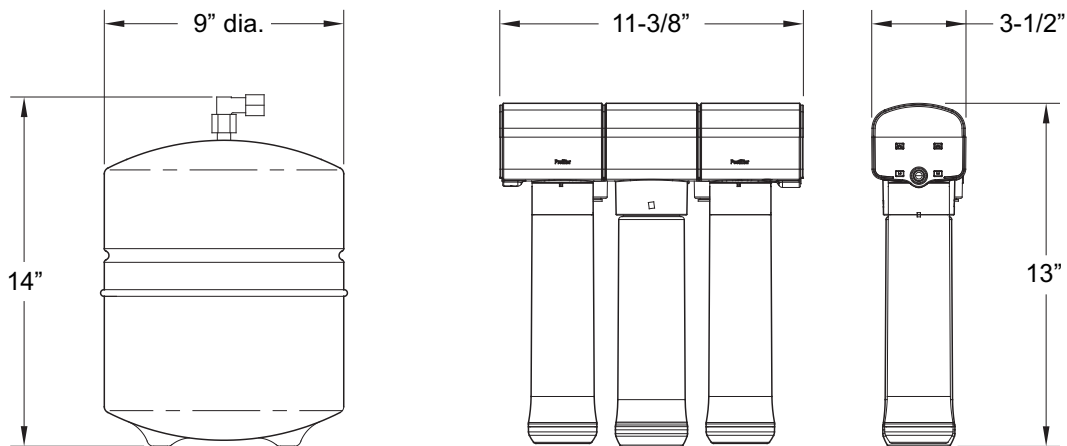

PRETREATMENT OF THE WATER SUPPLY NEEDED TO PREVENT SCALING

TO USE THE CHART...

...Locate the intersecting point of feed **water hardness** and **pH**.

If this point falls within the shaded area, pretreatment* is needed.

*Softening of the water is the suggested pretreatment.

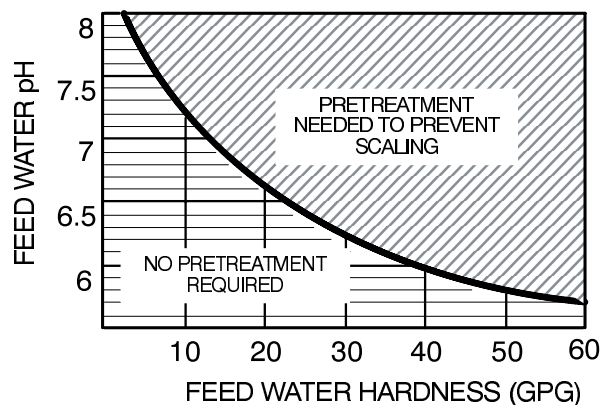

WHAT THE DRINKING WATER SYSTEM WILL DO

The drinking water system is a REVERSE OSMOSIS (RO) water treating unit. Reverse osmosis is a way of reducing dissolved solids and organic matter from water by passing it through a special membrane. The membrane separates minerals and impurities from the water, and they are flushed to the drain. Good tasting, high quality product water goes directly to the drinking water faucet, or to the storage area. The system makes a good supply of drinking water each day (see specifications). How much it will make depends on the feed water supply pressure, temperature, and quality.

Pre and postfilters are replaceable cartridges. The carbon prefilter reduces some chlorine (see specifications) while also filtering sediments. The postfilter reduces any other undesirable tastes and odors before you use the water.

The RO system also includes a standard faucet assembly to vend the drinking water, and a storage tank.

NOTE: A performance data sheet is included listing what the system will reduce from the water supply. See performance data sheet for individual contaminants and reduction performance.

The drinking water system fits under the kitchen or bathroom sink. However, you can install it where most convenient. You do need a COLD water supply pipe and drain point within a few feet (6' tubing lengths included). You can buy longer lengths of tubing if needed to reach more distant points. Be sure tubing is acceptable for use on potable water supplies.

COMPONENTS OF THE SYSTEM

The RO system is shipped in one carton, consisting of:

- (1) Storage Tank,
- (2) Faucet,
- (3) RO Assembly, with color coded tubing lengths attached,
- (4) Parts bag containing storage tank connector, drain flow restrictor, mounting washers and screws.
- (5) Separate 30" length of 3/8" tubing.

INSTALLER PROVIDES: (1) fittings to tap the cold water pipe for a feed water source to the RO . . . must adapt to 1/4" tubing; and (2) a drain point for RO discharge water . . . must adapt to 3/8" OD tubing. Both items must comply with state and /or local codes.

Optional fittings are available from EcoWater for use in areas where codes permit.

THINGS TO CHECK BEFORE YOU START TO INSTALL:

★ **FEED WATER** - The water supply to the Drinking Water System must have the qualities listed in the specifications. If not, it will not make product water as it should and life of the RO membrane is shortened. City water most often will have these qualities. Well water may need conditioning. Have the water tested by a water analysis laboratory, and get their recommendations for treatment. Check and comply with local plumbing codes when providing a water supply to the RO. Refer to pages 16 and 19.

NOTE: Codes in the state of Massachusetts require installation by a licensed plumber, and do not permit the use of the drain clamp. For installation, use plumbing code 248-CMR of the Commonwealth of Massachusetts.

CAUTIONS:

Feed water must have chlorine reduced (prefilters reduce up to amount shown in specifications, page 3). Chlorine will destroy the RO membrane cartridge. Be sure to service the prefilters, page 12.

★ **DRAIN POINT** - A suitable drain point (check your local plumbing codes) is needed for reject water from the RO membrane cartridge. Running the RO drain tubing directly to a floor drain, laundry tub, sump, standpipe, etc., is preferred. If that is not possible or practical, using the sink p-trap drain pipe is suggested. A drain clamp (drilling required), or a special drain adapter are available from EcoWater to use where codes permit. Refer to pages 16 and 19. These options install on the sink drain pipe tailpiece, above the p-trap.

★ **RO FAUCET** - The RO product water faucet installs on the sink, or on the countertop next to the sink. Often, it's installed in an existing sink spray attachment hole. Space is required underneath for tubing to and from the faucet, and for securing it in place. Refer to pages 6 and 9.

★ **MOUNTING SURFACE** - The RO assembly mounts on a wall surface under the sink, or you can lay it on the bottom of the cabinet. Special washers and screws are included for wall mounting. When the storage tank is full of water, it weighs about 30 pounds. Be sure to set on a surface that will support this weight.

INSTALLATION - FEED WATER SUPPLY

Check and comply with local plumbing codes as you plan, then install a cold feed (supply) water fitting. The fitting must provide a leak tight connection to the RO 1/4" OD tubing, see Figure 5, page 9. A typical installation, using standard plumbing fittings is shown in Figure 1. A saddle valve (not available from EcoWater) may be used where codes permit. Installation instructions are on page 16.

NOTE: Codes in the state of Massachusetts require installation by a licensed plumber, and do not permit the use of the drain clamp. For installation, use plumbing code 248-CMR of the Commonwealth of Massachusetts.

PIPE FITTINGS (compression shown)

IMPORTANT: Before starting, close the hot and cold water shutoff valves (See Figure 1). Use a pan to catch water when disassembling the pipe.

Complying with plumbing codes, install a fitting on the kitchen cold water pipe to adapt 1/4" OD tubing. A typical connection is shown in Figure 1. You can use solder or threaded fittings. If threaded fittings are used, be sure to use pipe joint compound or Teflon tape on outside threads.

Do not connect the tubing to the fitting until step 2, top of page 9.

FIGURE 1

WATER SUPPLY TYPICAL CONNECTION
(using compression fitting)

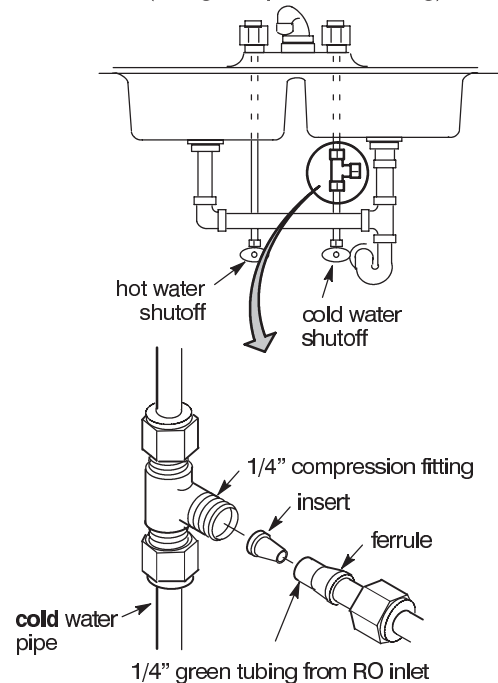

REJECT WATER DRAIN FITTING

Running the RO drain tubing directly to a floor drain, laundry tub, sump, standpipe, etc., is preferred. If that is not possible or practical, check and comply with local plumbing codes as you plan, then install a drain fitting for RO reject water. This fitting is usually installed at the sink p-trap (always above). It must provide a leak-tight connection to 3/8" OD tubing from the RO product water faucet airgap, see Figure 5, page 9. Typical drain fittings are listed below. A drain adapter (part no. 7192230) is available to use where codes permit. Installation instructions are on page 16. Other options are shown on page 19.

"Y" BRANCH TAIL PIECE, OR OTHER APPROVED P-TRAP DRAIN

Reject water from the RO is routed to the RO faucet airgap (1/4" tubing), then to the drain point with 3/8" OD tubing. **COMPLYING WITH PLUMBING CODES,** install a fitting to accept the 3/8" tubing. Figure 2 shows typical p-trap and "Y" branch tail piece type drains.

Do not connect drain tubing until step 1, top of page 9.

FIGURE 2

DRAIN TYPICAL CONNECTION
(check local codes)

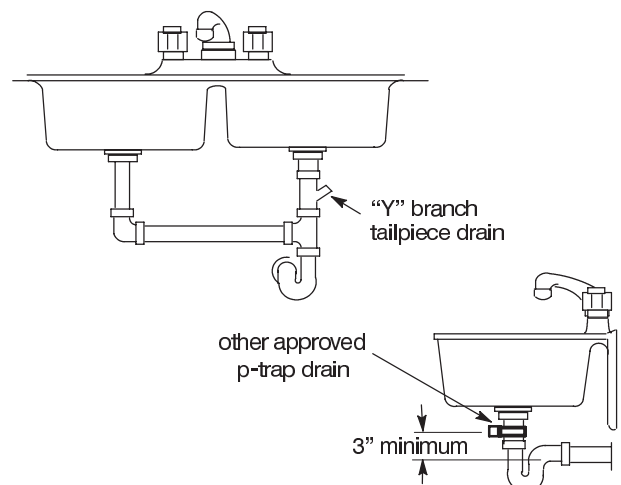

INSTALL THE FAUCET

Select one of the following places to install the faucet. Be sure there's room underneath so you can make the needed connections.

- ◆ In an existing sink spray attachment hole.
- ◆ Drill a hole in the sink top.
- ◆ Drill a hole in the countertop, next to the sink.

NOTE: Looking at Figure 3, be sure the faucet base will fit flat against the surface at the selected location so the o-ring will seal.

1. Locate and organize your RO faucet install parts. Refer to Figure 3.

2. Mount faucet base to sink hole until the faucet base is square against the sink surface. The rubber washer should be between the sink surface and the faucet base. See Figure 3.

3. Tighten the toggle bolts until the base is firmly mounted to the sink surface. Do not overtighten.

4. Move the RO system into position, under the sink. (Referring to page 7, hang the system on cabinet wall, or lay on the floor surface, as desired.)

NOTE: See tubing connection procedures on page 8. For ease of service and maintenance, keep tubing lengths long enough so removal of the RO system from under the sink is possible.

5. Feed a length of 3/8" blue tubing up through the hole and connect to the 3/8" quick connect fitting on the bottom of the faucet. See Figure 4. The other end of this tubing will be connected to the RO system, as shown on page 9.

NOTE: If you will route the red RO drain tubing directly to the drain point, disregard steps 6 and 7 and refer to instructions on top of page 9.

6. Feed a length of 1/4" red tubing up through the hole and connect to the 1/4" barb on the bottom of the faucet. See Figure 4. The other end of this tubing will be connected to the RO system, as shown on page 9.

7. Feed a length of 3/8" black tubing up through the hole and connect to the 3/8" barb on the bottom of the faucet. See Figure 4. The other end of this tubing will be connected to the drain, as shown on page 9.

8. Mount the faucet body on to the faucet base, 1/4 turn. See Figure 3.

INSTALL THE FAUCET

FIGURE 3 - FAUCET INSTALLATION

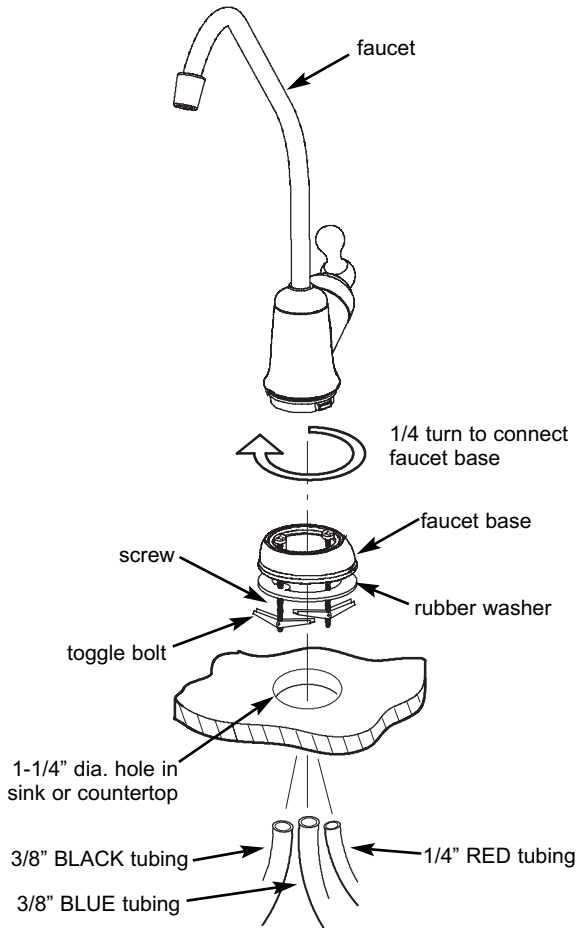
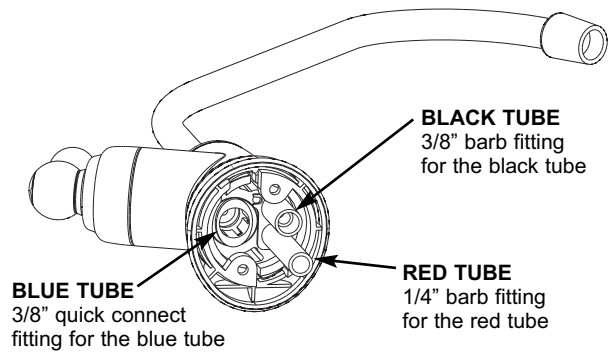

FIGURE 4 - TUBING CONNECTIONS



INSTALL RO ASSEMBLY AND STORAGE TANK

1. Hold the RO assembly up to the wall surface where you will install it. Mark locations for the hanger washers and screws.

2. Fasten the hanger washers to the wall surface. Wood screws are included for fastening to a wood surface. Provide other screws for other surfaces as needed.

3. Hang the RO assembly on the hanger washers.

4. Move the storage tank into place, setting on the floor surface. Use the stand, included with the tank, and position the tank upright, or on its side.

5. Apply teflon tape on the tank nipple threads and install the tank connector.

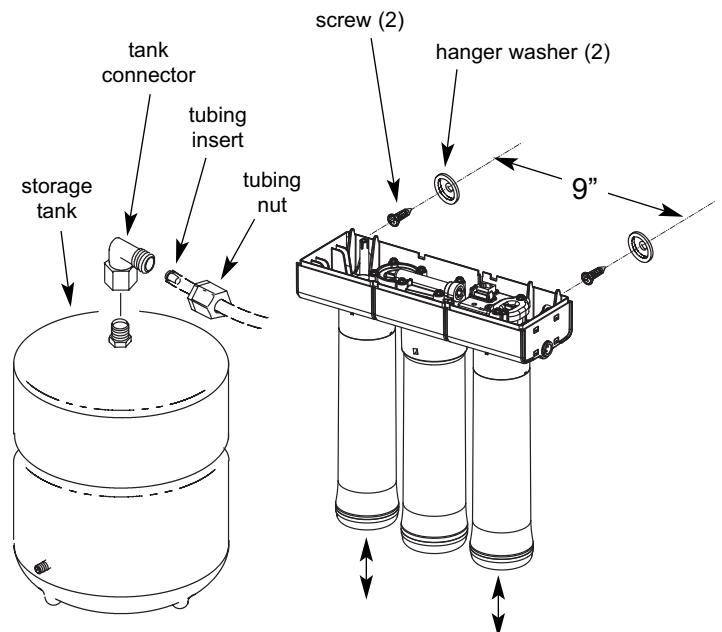

NOTE: Be sure to allow a minimum space of 1-1/2" under the system for removing the cartridges in order to change them.

TUBING CONNECTIONS

HOW TO CUT AND CONNECT THE TUBES

Your Reverse Osmosis Water System includes push-in fittings for quick tubing connection. Review the following instructions before connecting the tubes in the next step.

Cut tubes to length

1. Use a sharp cutter or knife to cut the end of tubing. Always cut the tubing square.

2. Inspect the end (about 1") of the tubing to be sure there are no nicks, scratches or other rough spots. If needed, cut the tubing again.

NOTE: Tubing lengths should allow for the removal of the assembly from the hanger washers for servicing. If tubing lengths are shortened for neater appearance, it may be necessary to keep the assembly on the hanger washers for service.

Connect tubes

NOTE: Remove protective foam plugs before connecting tubes. Discard foam plugs.

1. Push tubing through collet, until it engages the o-ring. Continue pushing until the tube bottoms out against the back of the fitting. A common mistake is to stop pushing when the tube engages the o-ring. This will lead to future leaks. When a 1/4" tube is fully engaged, 11/16" of the tube has entered the fitting. When a 3/8" tube is fully engaged, 3/4" of the tube has entered the fitting.

2. If using tubing other than tubing supplied with the system, be sure it is of high quality, exact size and roundness with a smooth surface.

To Disconnect Tubes

1. Push the collet inward with a finger tip.
2. Continue holding collet inward while pulling the tubing out.

Remove and Discard Foam Plugs

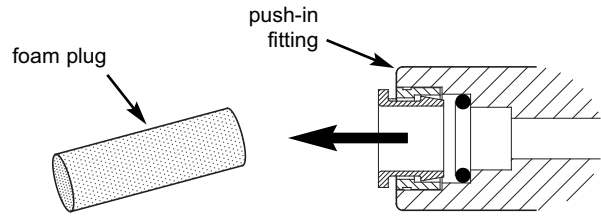

Tube Correctly Cut

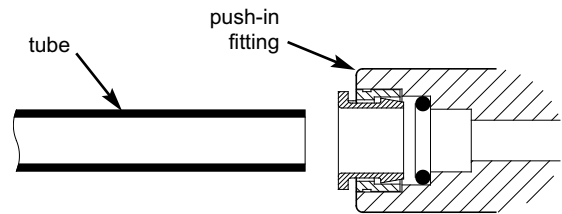

Cut tubing square with end of tubing round, smooth, with no cuts, nicks or flat spots.

Tube Partially Engaged With Fitting

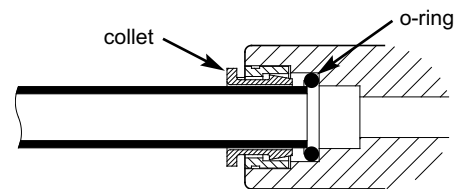

Tube Fully Engaged With Fitting

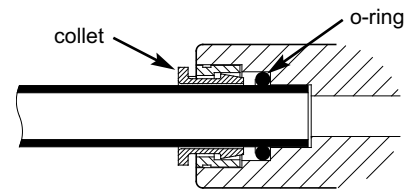

Disconnect Tubing

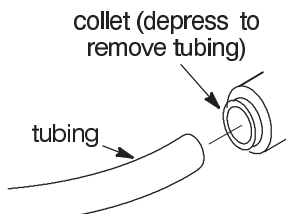

Collet and O-ring

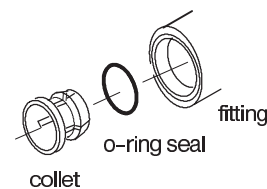

SANITIZING THE RO SYSTEM

SANITIZE THE SYSTEM

Sanitizing is recommended immediately after installation of the Reverse Osmosis system. It's also recommended after servicing inner parts. It is important that the person installing or servicing the system have clean hands while handling inner parts of the system.

Complete the following steps to sanitize the system.

1. Turn off the water supply to the Reverse Osmosis system, or remove prefilter to automatically shut off water supply.
2. Open the Reverse Osmosis faucet. If the tank is not already empty, allow the water to empty.
3. Use an eyedropper or other suitable tool, and common household bleach (5.25%).

4. Add 3 mL. of bleach into open end of yellow tank tubing. Handle bleach according to bleach manufacturers recommendations.

5. Connect yellow tank tubing to tank connector. Run the length of 3/8" yellow tubing from the RO to the tank connector at the top of the storage tank (Figure 5).

6. Sanitizing the system will be completed during the pressure test and purging steps below.

NOTE: The bleach must be removed from the system before drinking the water. See purging instructions below.

PRESSURE TESTING

DO THE PRECEDING SANITIZING PROCEDURES BEFORE PRESSURE TESTING.

1. Open the water supply shutoff valve to the RO.
2. Open the main water supply valve and several house faucets to purge air from the system. Close faucets when water runs smooth.

3. In about two hours, pressure will start to build in the RO system. Then, carefully check all fittings and connections for water leaks. Correct leaks if any are found.

PURGING THE SYSTEM

To purge the system, complete the following steps.

1. Open the RO faucet and let water flow through the system for a 24 hour period.

NOTE: Water flow may be a slow trickle at this time.

2. Close the RO faucet after the 24 hour purging period is complete.

3. When the purging is finished, your Reverse Osmosis system is ready for use.

HOW THE RO SYSTEM WORKS

PREFILTER

Water from the cold supply pipe enters the RO assembly sediment prefilter first. The replaceable sediment cartridge reduces chlorine, sand, silt, dirt, other sediments to clean the feed water before entering the RO cartridge and postfilter.

REVERSE OSMOSIS (RO) CARTRIDGE

The cartridge, inside the RO housing, includes a tightly wound, special membrane. Water is forced through the cartridge and the membrane reduces the dissolved solids and organic matter. High quality product water exits the RO housing and goes to the storage tank, or to the postfilter and RO faucet. Reject water, with the dissolved solids and organic matter, is routed through the flow control and to the drain.

STORAGE TANK

The storage tank holds product water. A diaphragm inside the tank keeps water pressurized when the tank is full, to provide fast flow from the RO faucet. The tank is charged with 5-7 psi air.

POSTFILTER

After leaving the storage tank, but before going to the RO faucet, product water goes through the postfilter. The postfilter is an activated carbon type filter. Any remaining tastes, odors and sediments are reduced from the product water. Clean, high quality drinking water is available for use.

FAUCET

The sink or countertop faucet vends the drinking water when opened. It is opened and closed by turning the knob. To comply with plumbing codes, an air-gap is built into the faucet drain water connection.

SHUTOFF ASSEMBLY

To conserve water, the drinking water system has an automatic shutoff system. When the storage tank has filled to capacity, and the drinking water faucet is closed, pressure closes the shutoff to stop flow into the RO. After drinking water is used, and pressure in the system drops, the shutoff opens to allow water flow again.

CHECK VALVE

A check valve is located in the RO manifold, above the center sump. The check valve prevents a backward flow of product water from the storage tank. A backward flow could rupture the RO membrane.

FLOW CONTROL

Water flow through the RO membrane is regulated by the flow control. It maintains the desired flow rate to obtain the highest quality drinking water. The flow control is located in the 1/4" red drain tube. A small cone-shaped screen fits over the end of the flow control to help prevent plugging with drain water sediments.

CARE OF YOUR REVERSE OSMOSIS SYSTEM

To keep your reverse osmosis system operating and producing high quality water, you must make sure supply water is always within the limits shown in the specifications. Good supply water helps to assure longer life from the RO membrane cartridge, prefilter and postfilter cartridges. However, each of these will wear out in time and need replacement.

This reverse osmosis system contains a replaceable treatment component critical for effective reduction of total dissolved solids. The monitor faucet feature provides continuous analysis of the systems performance. For systems not equipped with the monitor faucet function, it is highly recommended that you have your water tested at least every 6 months to verify your system is performing properly. Test kits are available by calling 1-800-949-8220, or check the water testing section of your local phone directory.

If the RO assembly is wall mounted, you may be able to replace parts with the assembly left on the wall. If not, simply lift the RO assembly from the mounting washers and lay on the cabinet floor when replacing the prefilter and post filter cartridges and RO membrane.

PREFILTER AND POST FILTER CARTRIDGES

You must replace the prefilter cartridge often to protect the RO membrane from being destroyed by chlorine, and/or from plugging with sediments in your water supply. If the water supply contains both chlorine and sediments, replace the prefilter cartridge at least every 6 months of product water use. Replace more often than 6 months if it begins to plug with sediments.

If the water has sediments only, with no chlorine, you may notice a slower making of product water as the prefilter collects the sediments. When this occurs, replace the prefilter cartridge. Also replace the post filter cartridge.

To replace the filter cartridges, see Figure 6:

1. Remove (turn to the left) the prefilter cartridge from the filter head.
2. Remove the postfilter cartridge (turn to the left) the postfilter cartridge from the filter head.
3. Discard both cartridges in a proper manner.
4. Insert new cartridges, starting with the post filter, turning to the right to reattach the cartridges.
5. It is recommended to discard the first full tank after the filters have been changed to minimize carbon fines.

RO MEMBRANE CARTRIDGE

This reverse osmosis system contains a replaceable component critical to the efficiency of the system. Replacement of the reverse osmosis component should be one with identical specifications, as defined by the manufacturer, to assure the same efficiency and contaminant reduction performance.

The life of the RO membrane cartridge depends mostly on the pH and hardness of the supply water to the RO system (see specifications). Cartridge life is shorter with higher pH. For example, if supply water pH is from 6.8 to 7.7, the cartridge may last for well over one year. However, cartridge life may be as short as 6 months if the pH is as high as 8.5 to 10. Higher pH weakens the cartridge membrane and causes pin-hole leaks.

It's time to replace the RO cartridge when the production

continued on page 13

FIGURE 6

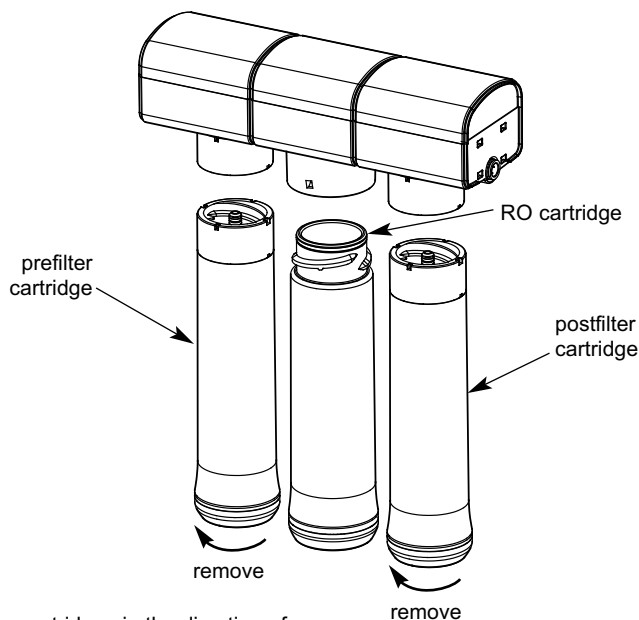

Turn cartridges in the direction of the arrow to remove. Turn them in the opposite direction to install.

CARE OF YOUR REVERSE OSMOSIS SYSTEM

continued from page 12

rate and/or quality of product water drops. Product water may begin to taste different or bad, indicating solids and organics are passing through the RO membrane. When replacing the RO cartridge, replace the prefilter and post-filter cartridges as well.

To replace the RO cartridge (see Figure 6):

1. Remove (turn to the left) the pre filter cartridge from the filter head to relieve pressure on the Reverse Osmosis cartridge.
2. Remove the RO cartridge.
3. Remove the post filter cartridge.
4. Discard the cartridges in a proper manner.
5. Install new cartridges in reverse order (post filter, Reverse Osmosis and then prefilter). Turn cartridges to the right to re-attach to the filter heads.
6. Purge the RO membrane cartridge following instructions on page 10.

FLOW CONTROL

The flow control is vital for proper operation of the RO membrane cartridge. The control keeps water flow through the membrane at the needed rate to obtain the best quality product water.

Periodically check the flow control to be sure the small hole through it is clean and unrestricted.

AUTOMATIC SHUTOFF / PADDLEWHEEL SERVICE

If either the shutoff assembly or paddlewheel requires service, be sure to reassemble parts exactly as shown below.

FIGURE 8

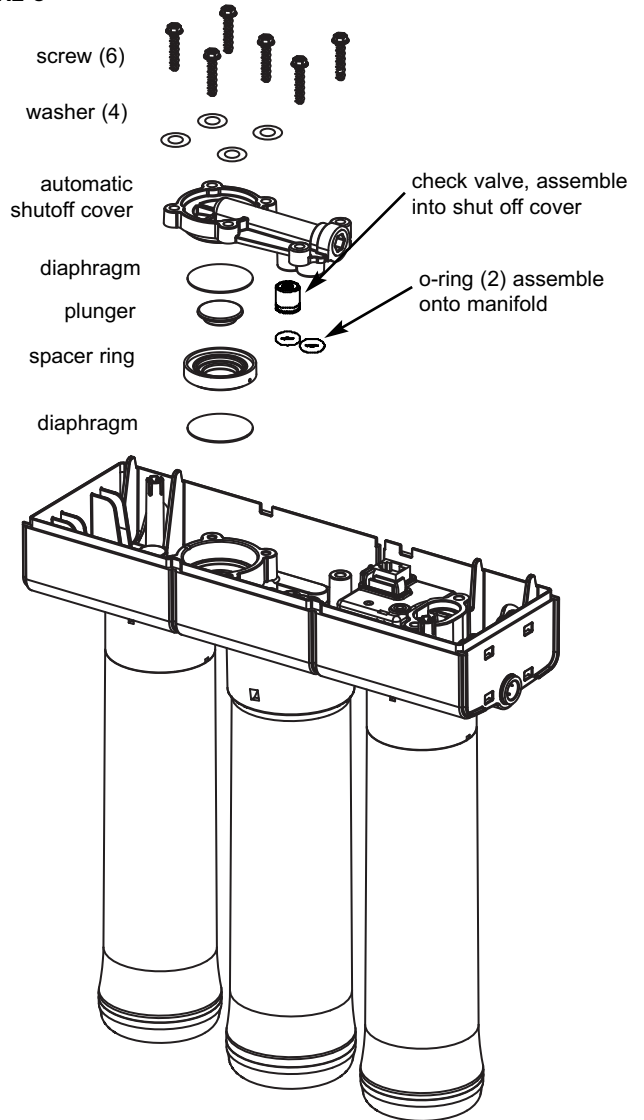
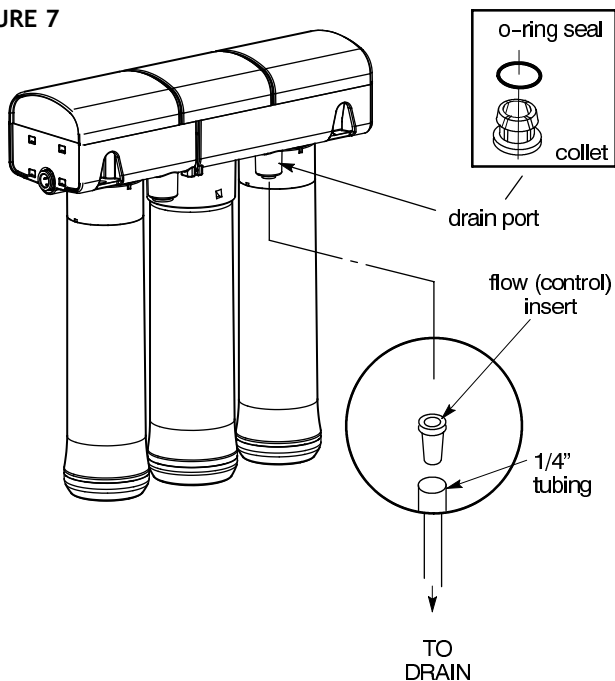

FIGURE 7



CARE OF YOUR REVERSE OSMOSIS SYSTEM

REVERSE OSMOSIS SYSTEM CARE GUIDE MODEL NO. ERO-175

1. AT LEAST every 6 months, replace the prefilter and postfilter cartridges.	
2. Replace the RO membrane cartridge when the percent rejection of total dissolved solids (TDS) is less than shown in the specifications (see B, below).	
If any of the following occur before the 6 months, replace as directed.	
A. Slow Making of Product Water: Replace the prefilter cartridge. If the production rate does not improve, replace the post filter cartridge and RO membrane cartridge.	C. Chlorine Taste and/or Odor: Replace the prefilter, post filter and RO membrane cartridges.
B. High Total Dissolved Solids (TDS) in Product Water: If water quality is in question, contact your local dealer for testing. It is important to test both the treated and untreated water to determine system performance. If the TDS is not within the system's performance guidelines, replace the pre-filter, post filter and RO membrane cartridges.	

OTHER TROUBLESHOOTING

PROBLEM	CAUSE	CORRECTION
Chlorine taste and/or odor in the RO product water.	The amount of chlorine in your water supply exceeds maximum limits, and has destroyed the RO membrane.	If the water supply contains more than 2.0 ppm of chlorine, additional filtering of the water supply to the RO is needed. Correct this condition before doing maintenance on the RO system. Replace the prefilter, post filter and RO membrane cartridges.
	The prefilter is no longer removing chlorine from the water supply.	
Other taste and/or odor.	Post filter expended.	Replace the post filter cartridge. If taste and odor persists, replace the prefilter cartridge and RO membrane cartridge.
	RO membrane cartridge expended.	
	Contamination in product water storage.	Use sanitizing procedures. Replace the post filter cartridge.
System makes product water too slowly.	Water supply to the RO system not within specifications.	Increase water pressure, precondition the water, etc., as needed to conform before doing maintenance on the RO system.
	Prefilter or RO membrane cartridges plugged with sediments or fouled.	Replace the prefilter cartridge. If rate does not increase, replace the postfilter cartridge and RO membrane cartridge.
	Flow Control Insert plugged.	Check and clean Flow Control Insert.
System makes lower amount of product water than usual.	Storage tank air-charge less than 5 - 7 psi.	Open RO faucet and drain tank until flow slows to a drip. Keep faucet open and check tank pressure. If low, pressurize to 6 psi. Close faucet to refill the tank.
High total dissolved solids (TDS) in product water - flashing red LED.	Water supply to the RO system not within specifications.	Increase water pressure, precondition the water, etc., as needed to conform before doing maintenance on the RO system.
	RO membrane cartridge expended.	Replace the prefilter, postfilter and RO membrane cartridges, flow control, and screen.
Water leaking from faucet airgap hole.	Drain side of faucet airgap (3/8" tubing) plugged, restricted, or incorrectly connected to drain point.	Inspect and eliminate restriction or plug. Refer to installation instructions for proper drain connection.
Continual water flow to drain.	Check valve or automatic shutoff assembly plugged, restricted or parts worn.	Clean, repair or replace as needed.
Continual high water flow to drain and no product water.	Missing flow restrictor in red drain tube or its corresponding port.	Replace flow restrictor.

REVERSE OSMOSIS SCHEMATIC

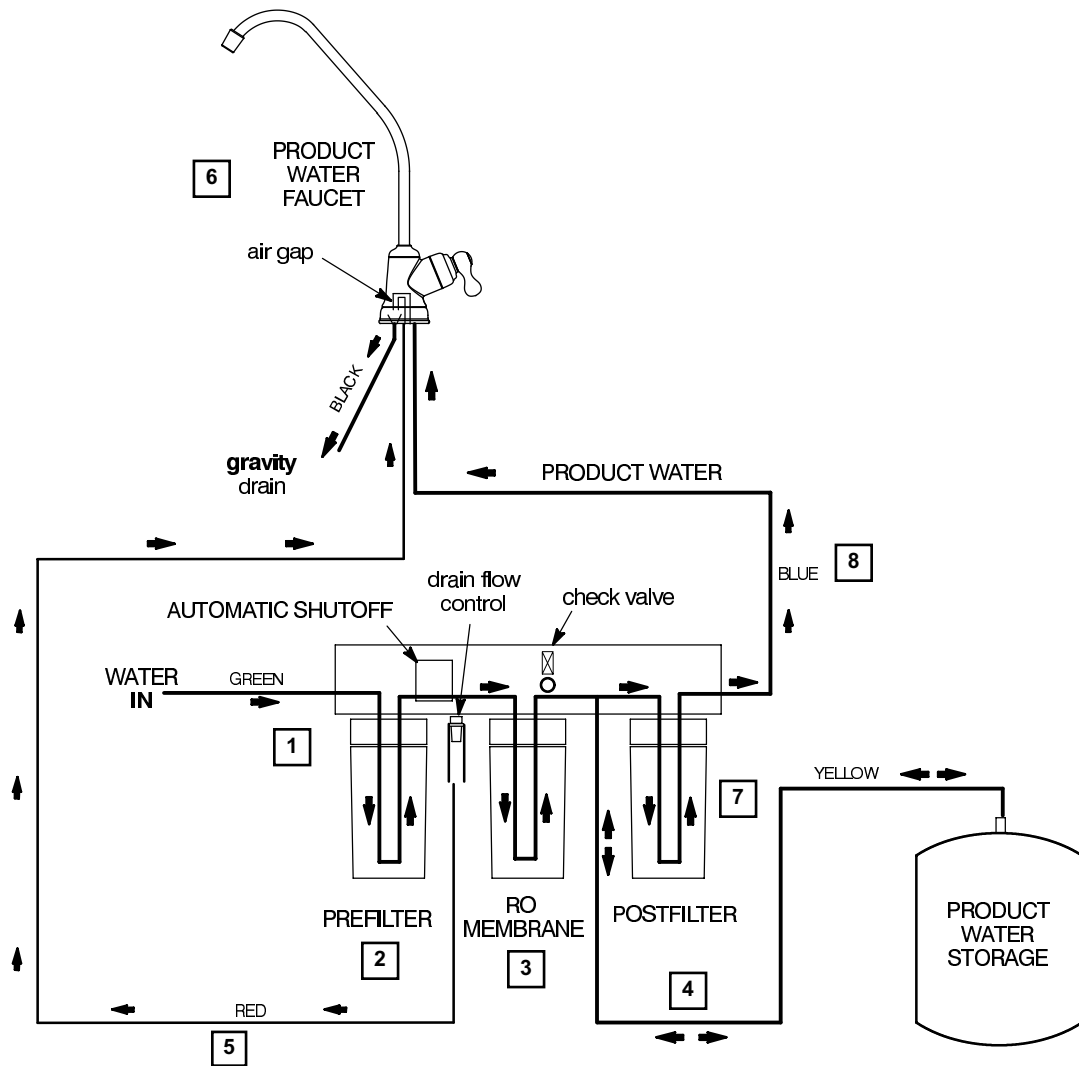

Water Flow Description

1. Water enters prefilter. Sand, silt and other sediments are reduced. Chlorine is also reduced.
2. Water leaves prefilter and proceeds to the Reverse Osmosis Cartridge.
3. Water enters the Reverse Osmosis membrane. Dissolved solids are reduced.
4. Processed water leaves the Reverse Osmosis Membrane and flows to the storage tank.
5. Waste water with dissolved solids leave the Reverse Osmosis membrane and flows to the drain.
6. Faucet is activated.
7. Processed water leaves the storage tank and flows to the post filter filtered to ensure fresh taste.
8. Water flows to the Reverse Osmosis faucet.

INSTALLATION OF OPTIONAL FITTINGS (not included)

SADDLE VALVE, not available from EcoWater

NOTE: This type of valve pierces a hole in copper tubing or plastic pipe. If installing on iron pipe, you have to drill a 1/8" pilot hole for the piercing pin. Be sure to turn off water to the pipe and to drain water from it before drilling. READ THE FOLLOWING DANGER NOTE.

DANGER (IF DRILLING METAL PIPE): To protect yourself from serious injury or fatal shock, use a battery powered hand drill only to make the hole. Do not use an electric drill.

1. Looking at Figure 23, turn the valve into clamp X and tighten (may be preassembled). Turn the valve handle all the way out.
2. Place the seal on the inside of clamp X as shown. Be sure the piercing pin does not stick out beyond the seal.
3. Place clamp X and Z around the pipe and secure in place with two screws. Tighten both screws evenly, but do not overtighten. Clamp Z will either have threaded screw holes, or two nuts are included.
4. Carefully turn the handle inward to pierce a hole in the copper or plastic pipe.

DRAIN ADAPTER, part no. 7192230

- The optional drain adapter installs in the sink drain pipe, always above or ahead of the p-trap. Be sure to comply with your local plumbing codes. Other drain pipe fittings, in addition to the adapter, may be needed.
- The drain adapter fits 1-1/2" sink drain pipe.
- The adapter installs directly onto the sink tailpiece as typically shown in Figure 23.
- Locate so drain tubing from the faucet makes a straight run to the adapter, without dips, loops, low spots or kinks.

NOTE: Consult a plumber if you are not familiar with plumbing procedures.

1. Use a ferrule and nut to assemble the drain tubing connector to the drain adapter. Turn the connector to about 45° from the 12:00 position, as shown (to 10:00 or 2:00 position as needed). Tighten the nut securely.
2. Carefully disassemble the sink drain pipe and clean the tailpiece to assure a leak-tight fit.

3. Install the drain adapter onto the sink tailpiece, using a ferrule and nut. Snug the nut, but do not tighten.
4. Assemble the p-trap to the drain adapter, and other drain pipe fittings as required (check codes) to complete the drain run.
5. Tighten all connections, but do not overtighten and break plastic fittings.

FIGURE 9

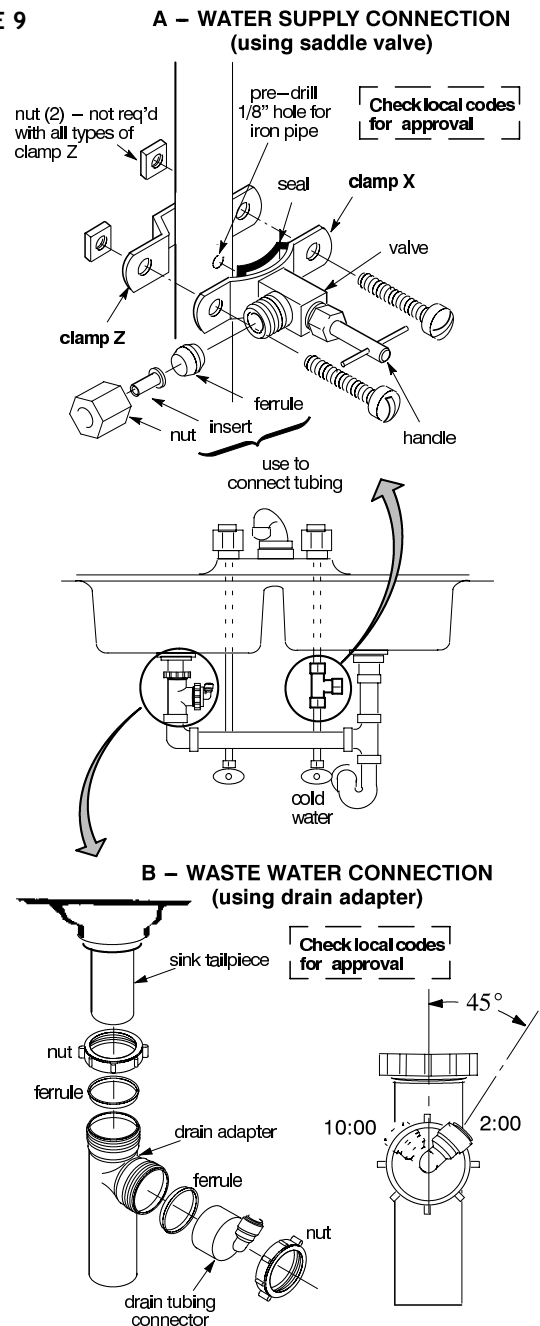

NOTE: Codes in the state of Massachusetts require installation by a licensed plumber, and do not permit the use of a saddle valve. For installation, use plumbing code 248-CMR of the Commonwealth of Massachusetts.

REMOTE LOCATION FOR REVERSE OSMOSIS SYSTEM

Possible remote locations for the RO nearby the kitchen or bathroom sink include;

- (1) a basement area underneath the sink, and
- (2) an adjacent room or closet.

Longer lengths of tubing (see parts list) and telephone cable extension (purchase locally*) may be needed.

You can run the drain tubing directly to one of several suitable open drain points, as shown below, bypassing the faucet airgap and p-trap drain. This type of drain is the preferred over the p-trap drain adapter. Check your local codes. Always be sure to provide an air gap between the end of the hose and the drain point of 2 pipe diameters or 1 inch, whichever is larger.

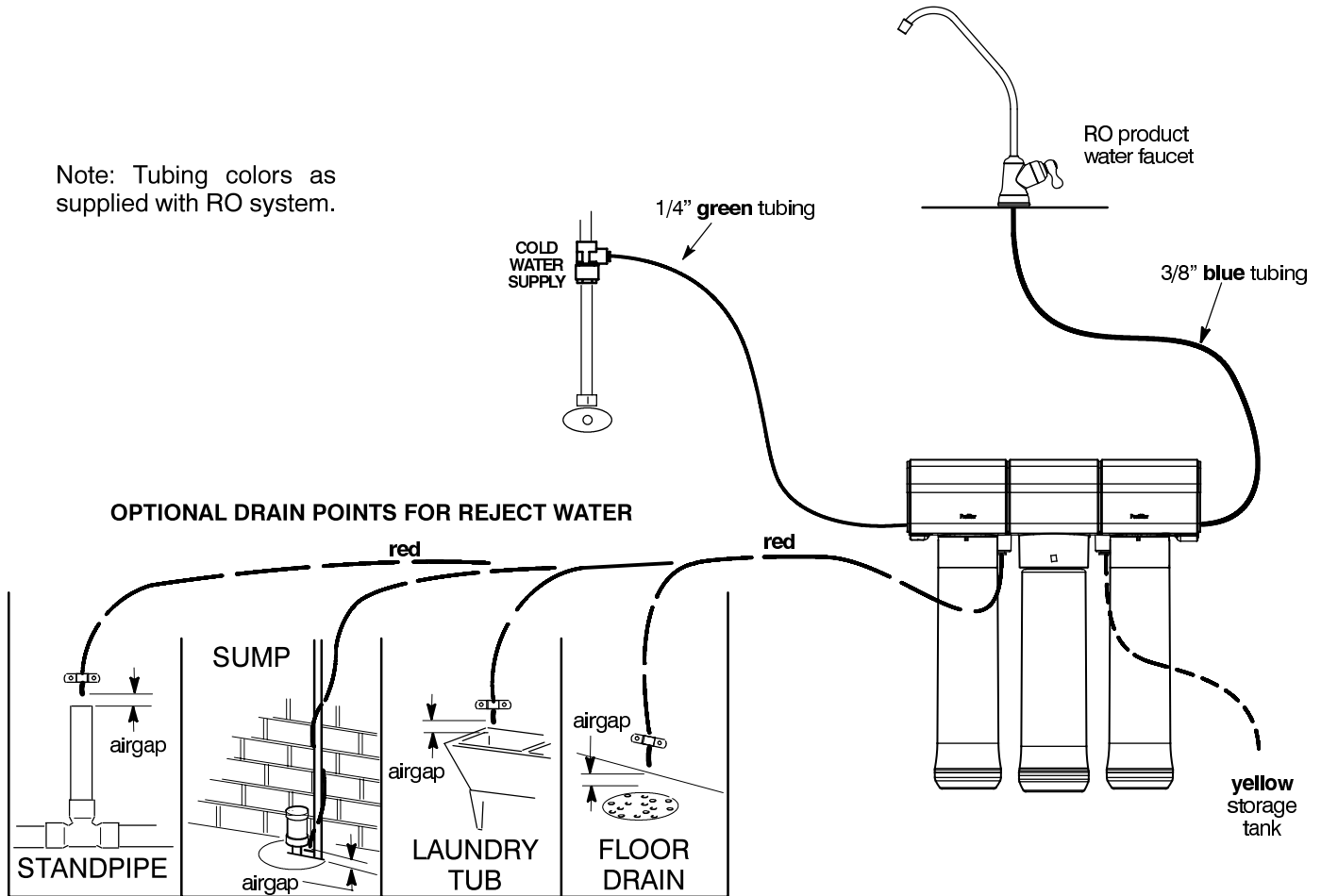

REPAIR PARTS

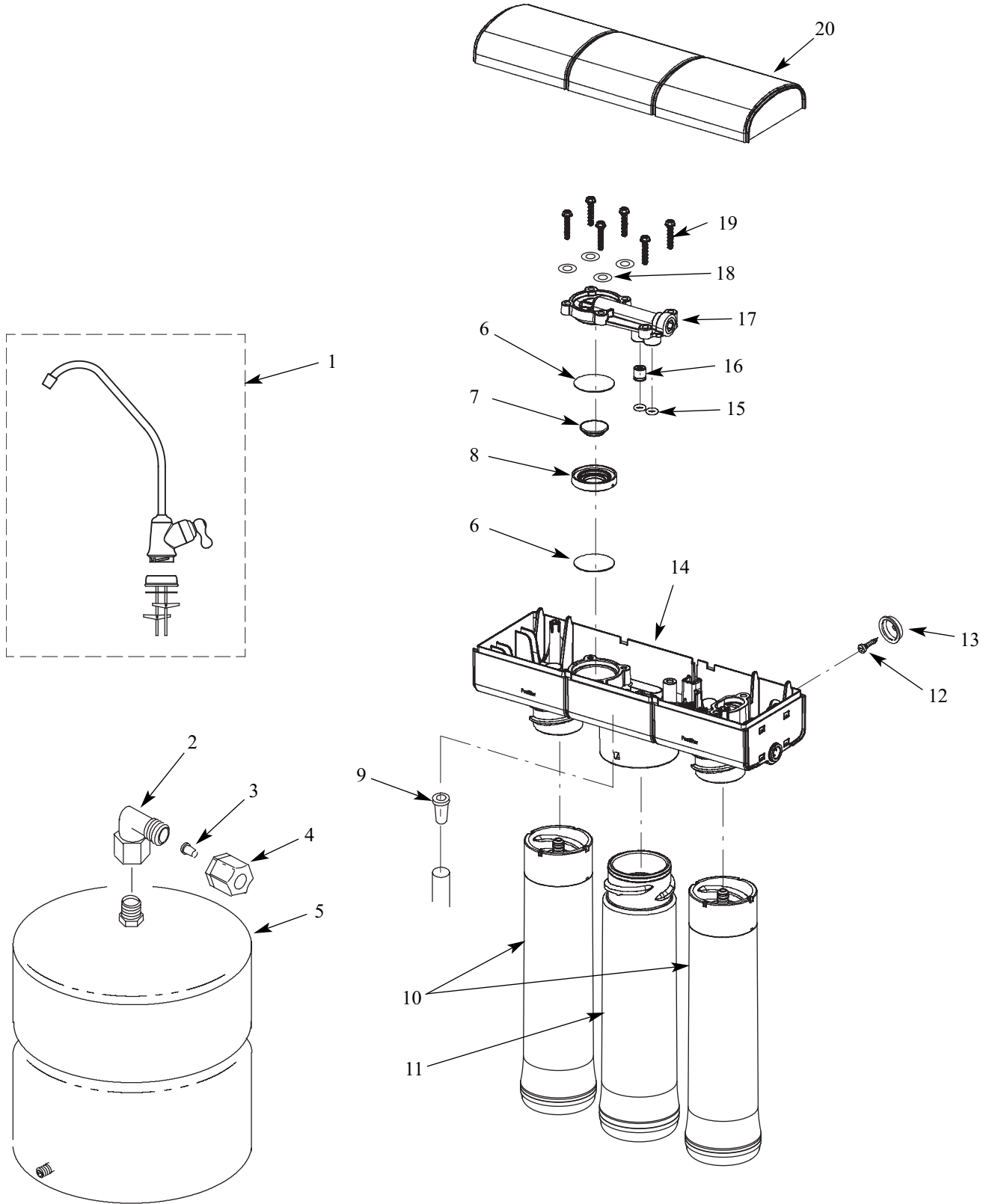

REPAIR PARTS

Key No.	Part No.	Description
1	7308043	Faucet with Base, Chrome
–	7333161	Tank Connector Kit (includes Key Nos. 2-4)
2	↑	Connector, 1/4 NPT x 3/8 Jaco
3	↑	Insert, 3/8" Tubing
4	↑	Nut, 3/8" Tubing
5	7205326	Storage Tank
–	7333179	Diaphragm Kit (includes Key Nos. 7, 8 & 2 of Key No. 6)
6	↑	Diaphragm (2 req'd)
7	↑	Plunger
8	↑	Spacer Ring
■	7095030	Cone Screen
9	7275185	Flow Control Insert
10	7308263	Pre / Post Filter Cartridge, CTO (2 req'd)
11	7308297	RO Membrane Cartridge, 42 gpd
–	7333129	Mounting Hardware Kit (includes 2 ea. of Key Nos. 12 & 13)
12	↑	Screw (2 req'd)
13	↑	Hanger Washer (2 req'd)

■ Not illustrated.

❖ Not included.

● Tubing lengths for remote installations and for direct replacement for colored lengths of tubing.

Key No.	Part No.	Description
14	7285384	Manifold Assembly (includes Key Nos. 6-8, & 15-19, assembled)
–	7333137	Check Valve Kit (includes Key No. 16 & 2 of Key No. 15)
15	↑	O-Ring, Auto. Shutoff Cover (2 req'd)
16	↑	Check Assembly
–	7333145	Automatic Shutoff Kit (includes Key No. 17, 4 of Key No. 18 & 6 of Key No. 19)
17	↑	Automatic Shutoff Cover Assembly
18	↑	Washer (4 req'd)
19	↑	Screw (6 req'd)
20	7272763	Cover
■	7273565	Flow Bend, 3/8" ❖
■	7273557	Flow Bend, 1/4" ❖
OPTIONAL ACCESSORIES and TUBING		
21	7227310	Tee, Feed Adaptor ❖
22	7208489	Drain Adaptor ❖
23	7079791	Drain Clamp ❖
■	7301203	Sanitization Kit ❖
■	7161823	Tubing, 1/4" x 20' - white ❖ ●
■	7157280	Tubing, 3/8" x 20' - white ❖ ●

To order parts call your local EcoWater dealer or go to www.ecowater.com to locate a dealer in your area.

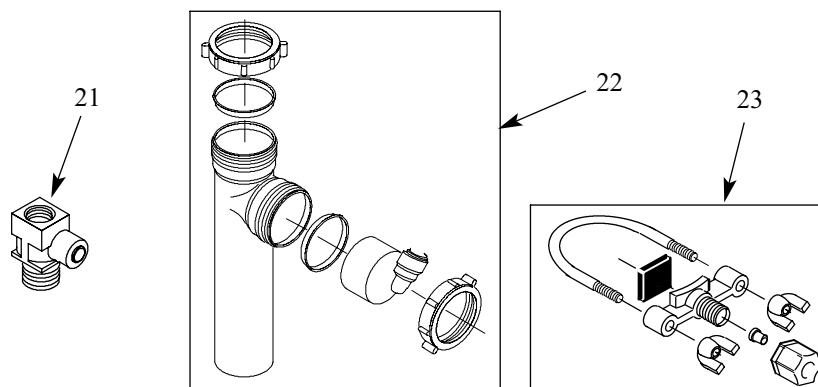

WARRANTY INFORMATION

LIMITED WARRANTY

1 and 5 YEAR

EcoWater Systems LLC, guarantees to the original owner that, for one (1) year from from the date of purchase, the entire drinking water system, including the reverse osmosis membrane, will be free from defects in material and workmanship. The RO holding tank will be guaranteed for five (5) years from defects in material and workmanship. The pre-filters and postfilter, which are expendable, are not covered under this warranty.

Any defective part, as described above, which fails within the one or five year period from date of purchase will be repaired or replaced, F.O.B. our plant, St. Paul, MN.

The sole obligation of EcoWater Systems LLC, under these guarantees, is to replace or repair the component or part which proves to be defective, within the specified time period, and EcoWater is not liable for consequential or incidental damages due to misuse, alteration, neglect, freezing or a force of nature. All implied warranties, including any implied warranty of merchantability or of fitness for a particular purpose, are disclaimed to the extent they extend beyond the above periods. No dealer, agent, representative, or other person is authorized to extend or expand these guarantees.

Some states do not allow limitations on how long an implied warranty lasts or exclusions or limitations of incidental or consequential damage, so the limitations and exclusions in this warranty may not apply to you. This warranty gives you specific legal rights, and you may have other rights which vary from state to state.